

가스 차브로일러 / 콘벡션오븐 (Gas Charbroiler With Convection Oven)

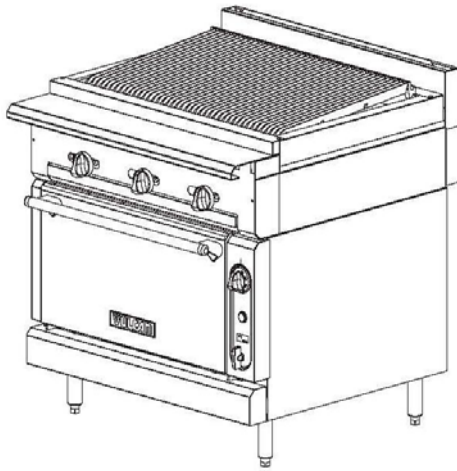

품 번				수 량
품 명	가스 차브로일러 / 하부 콘벡션 오븐			
모 델	VCBB36C			
규 격	가로 914mm x 세로 933mm x 높이 914mm			
능 력				
제 조 사	VULCAN-HART COMPANY (Made in : U.S.A)			
선적중량	346 Kg (763 LBS)			
에 너 지 제 원				
가 스	32A	LPG or LNG	발열량	37,548 Kcal
전 기	1P 115V 60Hz 4 Amps (Blower Motor)			

용 도

상부의 주물 그릴의 상판에 구이류의 음식을 타지 않도록 최상의 조리를 하는데 사용 합니다.
하부의 오븐은 구이류의 모든 조리과 제과 제빵용도의 오븐으로 사용이 됩니다.

주의 : 1) 파이롯트 버너의 불이 항상 켜져 있는지 확인하시기 바랍니다, 일과 중에는 항상 켜져 있어야 합니다.
2) 조리 작업 완료 후에는 중간 밸브 및 메인 밸브를 잠가 주어야 합니다.

제 품 사 양



- ☞ 전면, 상판 정면, 버너 박스, 측면 스텐레스로 제작
- ☞ 몸체 외부, 하부 및 상부후면 뿔 스텐레스로 제작
- ☞ 32A 상부 좌측 또는 우측 가스 연결 (후면 연결 가능)
- ☞ 24,948 Kcal/hr.(6개) 발열량의 샷갯형 주물 버너
- ☞ 8,064 Kcal/hr. 발열량의 콘벡션 오븐 버너
- ☞ 법랑 도색의 오븐 내부
- ☞ 각각의 파이롯트 버너를 이용한 점화 방식의 오픈 버너
- ☞ 내열에 강하고 견고한 경사형 빗살형 상판
- ☞ 스텐레스 버너 분리 차단 칸막이
- ☞ 100mm 높이의 오븐 배기구 기능을 겸한 스텐레스 뿔
- ☞ 152mm 높낮이 조절식 스텐레스 다리
- ☞ 분리식의 일체형 오븐 선반 레일
- ☞ 콘벡션 오븐 전기 사양 : 1P 115V 60Hz 4 Amps
- ☞ 오븐 내부 규격 685mm x 685mm x 330mm
- ☞ 79°C~287°C 온도 조절 기능의 콘벡션 오븐
- ☞ 3개의 오븐랙 삽입 가능
- ☞ 표준 오븐-1개 랙 / 콘벡션 오븐-2개 랙 제공

- ☞ Stainless steel front, front top ledge, burner box, side
- ☞ Stainless steel base, exterior bottom and stub back
- ☞ 1.25"(32A) diameter front gas manifold with 1.25" rear
- ☞ 99,000 BTU/hr. 6 burners
- ☞ 32,000 BTU/hr. convection oven burner
- ☞ porcelain oven cavity
- ☞ Individual pilots and controls for each burner
- ☞ Heavy-duty slant cast grates and char-radiants
- ☞ Stainless steel supercharger burners dividers
- ☞ 4" stainless steel stub back
- ☞ 6" adjustable stainless steel legs
- ☞ Pull-out cindiment rails
- ☞ Convection oven electric : 1P 115V 60Hz 4 Amps
- ☞ Oven measures 27"w x 27"d x 13"h
- ☞ 175°F~550°F convection oven thermostat adjusts
- ☞ Tree rack postions
- ☞ Standard oven 1-rack / Convection 2-Racks Supplied

제품인증



비 고



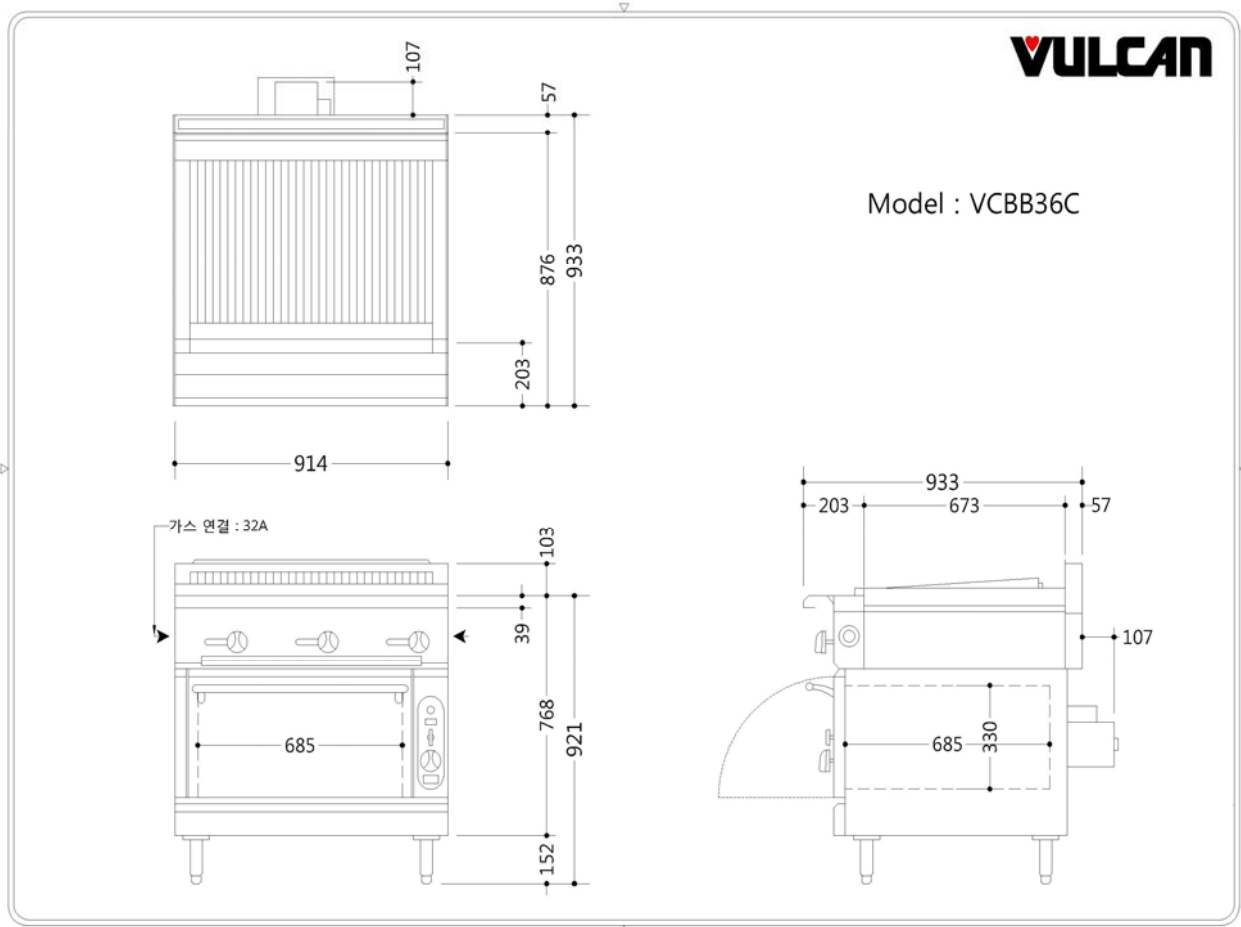

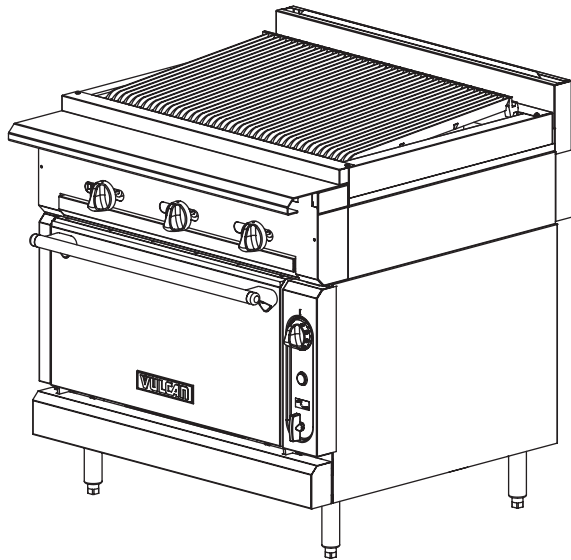
HEAVY DUTY COOKING**VULCAN****V SERIES HEAVY DUTY GAS RANGE
36" WIDE CHARBROILER****Model VCBB36S****SPECIFICATIONS**

36" wide heavy duty gas range, Vulcan model No. VCBB36 (modular), VCBB36B (cabinet base), VCBB36S (standard oven base) or VCBB36C (convection oven base). Modular construction for ease of installation. Stainless steel front, sides, plate ledge, front top ledge with pull-out condiment rails, stub back, and 6" adjustable legs on all "B", "S", & "C" models. Stainless steel extra deep crumb tray. Six burners, totaling 99,000 BTU/hr. Cast burners and char-radiants with stainless steel super-charger burner dividers. Individual pilots and controls for each burner. Heavy duty cast slant grates, easy lift off 6-each for 36" wide units. Standard oven: 50,000 BTU/hr. with porcelain oven bottom, sides, and interior door panel. Convection Oven: 32,000 BTU/hr. with porcelain oven bottom, sides, and interior door panel (115v-1phase blower motor, 4 amps, 6' cord & plug). Ovens measure 27"w x 27"d x 13"h. Standard oven thermostats adjust from 150°F - 550°F. Convection oven adjusts from 175°F - 550°F and the optional finishing oven for standard ovens adjusts from 300°F - 650°F. Standard oven supplied with one rack, convection oven with two. Both ovens allow for three rack positions. Oven door is heavy-duty with counter weight door hinges. 1¼" diameter front manifold and 1¼" rear gas connection, capped. Total input 99,000 BTU/hr.

Exterior Dimensions:

36¾"d x 36"w x 36"h on 6" adjustable legs

- VCBB36** 36" Charbroiler / Modular
- VCBB36B** 36" Charbroiler / Cabinet Base
- VCBB36S** 36" Charbroiler / Standard Oven
- VCBB36C** 36" Charbroiler / Convection Oven

STANDARD FEATURES

- Stainless steel front, front top ledge, burner box, sides, base, exterior bottom and stub back
- 1¼" diameter front gas manifold with ¾" rear gas connection (capped)
- 99,000 BTU/hr. (6 burners)
- 50,000 BTU/hr. standard oven burner
- 32,000 BTU/hr. convection oven burner
- Porcelain oven cavity
- Individual pilots and controls for each burner
- Heavy-duty slant cast grates and char-radiants
- Stainless steel supercharger burner dividers
- 4" stainless steel stub riser
- 6" adjustable stainless steel legs for "S", "C", & "B" units (no legs for modular unit)
- Stainless steel cabinet base doors
- One year limited parts and labor warranty

OPTIONAL FEATURES (Factory Installed)

- ¾" rear gas connection (capped)
- Cap and cover front manifold
- Stainless steel oven cavity
- 650°F oven thermostat and steel hearth. ("S" models)
- Fan cooling package ("C" models)
- 4" adjustable flanged feet for modular units
- 6" adjustable flanged feet for "S", "C", & "B" units
- Less legs for dolly mounting of cabinet base units
- Set of 4 casters, 6" high (two locking)
- 3" high toe base for curb mounting for "S", "C", & "B" units
- ¾", 1", or 1¼" gas pressure regulator (specify gas type)
- Universal rack guides, with one shelf (shelf is removable)
- Common condiment type, telescoping plate rails

ACCESSORIES (Packaged & Sold Separately)

- Extra removable shelves for use with Universal rack guides (cabinet base)
- Banking strip
- Common condiment type, telescoping plate rails (starting at 24" length)
- Straight, diamond cast, rod, and waffle/fish grates
- 10", 22", or 34" high back risers (no shelf)
- 22" single deck solid or flo-thru high shelf risers
- 34" double deck solid or flo-thru high shelf risers
- Dolly frames
- Flexible gas hose - quick disconnect & restraining device

VULCAN

a division of ITW Food Equipment Group LLC

P.O. Box 696 ■ Louisville, KY 40201 ■ Toll-free: 1-800-814-2028 ■ Local: 502-778-2791 ■ Quote & Order Fax: 1-800-444-0602



V SERIES HEAVY DUTY GAS RANGE
36" WIDE CHARBROILER

INSTALLATION INSTRUCTIONS

1. A properly sized gas pressure regulator suitable for battery or single unit application must be furnished and installed. Natural gas 6.0" W.C., propane gas 10 W.C.
2. An adequate ventilation system is required for commercial cooking equipment. Information may be obtained by writing to the National Fire Protection Association, 1 Batterymarch Park, Quincy, MA 02269, www.NFPA.org. When writing, refer to NFPA No. 96.
3. These units are manufactured for installation in accordance with ANSZ223.1A (latest edition), National Fuel Gas Code. Copies may be obtained from The American Gas Association, 400 N Capitol St. NW, Washington, DC 20001, www.AGA.org.

4. Clearances	Rear	Sides
Combustible	10"	10"
Non-combustible	0"	0"

5. For proper combustion, install equipment on adjustable legs or casters. On curb or platform, allow 3½" front overhand. Toe base with leveling bolts are required for curb installation. Specify when ordering.
6. Cannot be battered with GH series equipment.
7. This appliance is manufactured for commercial installation only and is not intended for home use.

NOTE: In line with its policy to continually improve its product, Vulcan reserves the right to change materials and specifications without notice.

Specify type of gas when ordering.
Specify altitude when above 2,000 feet.

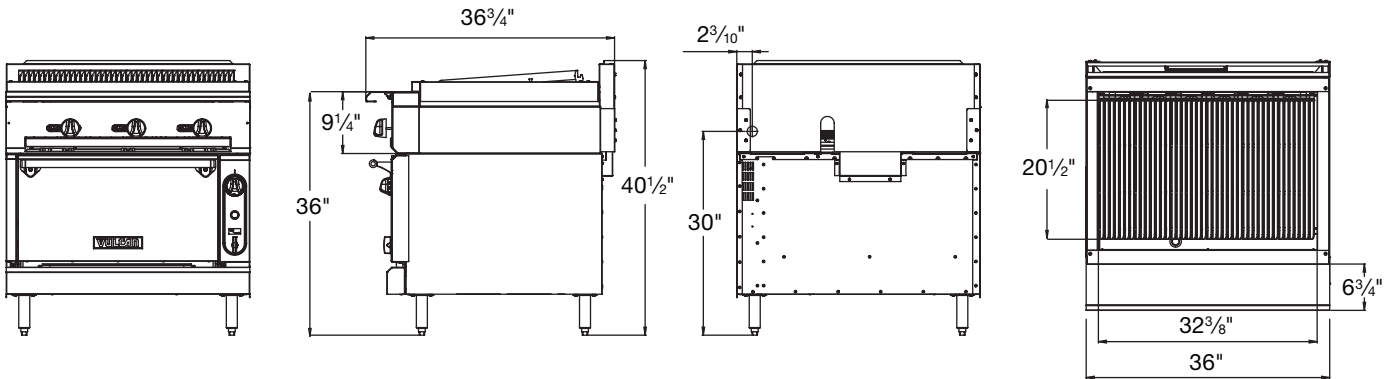

TOP CONFIGURATION	MODEL NUMBER	DESCRIPTION	TOTAL INPUT BTU / HR	SHIPPING WEIGHT LBS / KG
	VCBB36	36" Charbroiler / Modular	99,000	404 / 183
	VCBB36B	36" Charbroiler / Cabinet Base	99,000	504 / 229
	VCBB36S	36" Charbroiler / Standard Oven Base	149,000	685 / 311
	VCBB36C	36" Charbroiler / Convection Oven Base	149,000	763 / 346

This appliance is manufactured for commercial use only and is not intended for home use.



a division of ITW Food Equipment Group LLC

P.O. Box 696 ■ Louisville, KY 40201 ■ Toll-free: 1-800-814-2028 ■ Local: 502-778-2791 ■ Quote & Order Fax: 1-800-444-0602

NOTE: In line with its policy to continually improve its products, Vulcan reserves the right to change materials and specifications without notice.