



Model Description

- Capacity: up to 60 racks/h, or 2.160 glasses/h
- Cycle times: 60 / 90 / 120 sec. and special cycles
- Water consumption: 2,0 l/rack
- Tank capacity: 10,6 l
- Total loading: 6,8 kW | 3 x 25 A (380 / 60 / 3N)
- Wash pump: 0,5 kW
- Loading height: 300 mm
- Rack size: 500 x 500 mm
- Width x Depth x Height: 600 x 603 x 705 mm

- **TOP-DRY:** integrated drying technology – no need for manual drying
- **VAPOSTOP:** integrated steam condensation allows door opening without steam cloud. Also, no steam escape during the condensation phase
- **VISIOTRONIC-TOUCH control:** single button control with colour code and remaining cycle time indication. With colour display and touch.
- **WASHSMART APP:** controlling your warewash operation with smart technology: status and messages usage and operating cost, hygiene, order service and consumables
- **SENSO-ACTIVE resource management:** constantly measures the quality of the wash water and keeps the amount of rinsing needed in each rinse cycle to the minimum in order to guarantee a fully hygienic wash result
- **CLIP-IN wash and rinse arms:** wash and rinse arms can be removed with one hand and without any tools.

- **GENIUS-X** fine filter system: advanced filter system with prewash function reduces detergent consumption up to 35%
- **Cold rinsing**: the rinse can be switched from hot to cold water so that you get cooler glasses without any loss of time
- **Intensive program**: intensive rinse cycle to wash glasses with critical design with raised fresh-water amount
- **Interlocked strainer**: prevents operation without tank strainer
- **Hygiene program**: for removal of calcium carbonate and other deposits from wash chamber
- **Ready to install**: completely equipped: fill / drain hose, power cord (400 V connection), detergent dispenser, rinse aid dispenser, rinse pump, drain pump, backflow preventer
- 1 x Glass Rack 01-539040-001 (500x500mm)

Dimensional Drawing

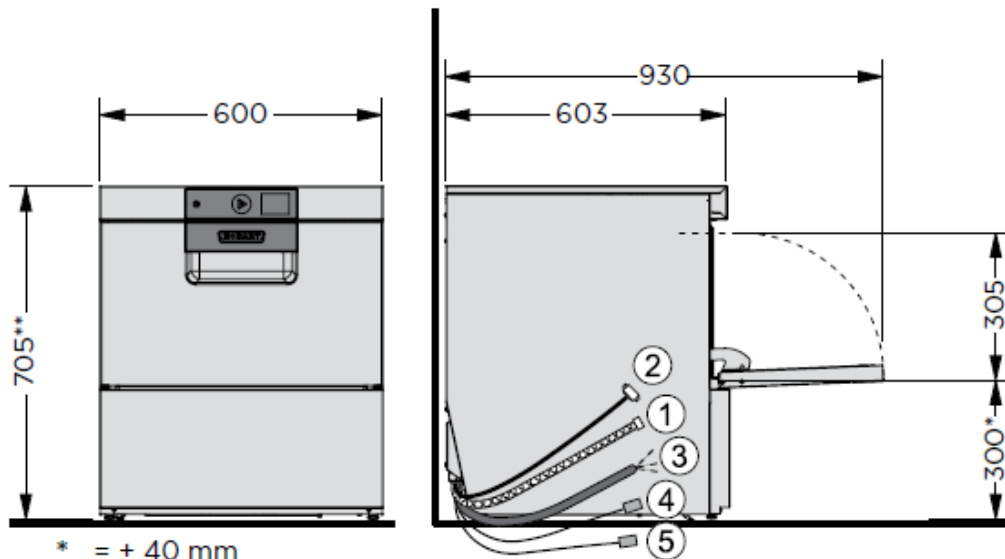

- 1 | Drain hose: 2.000 mm, ID20 / OD25
- 2 | Supply hose: 2.000 mm, R 3/4"
Flow pressure: 0,5-10 (with softener: 0,8-10) bar
Max. supply water temperature: 60 °C
Required flow rate: 5 l/min
- 3 | Power cord: 2.000 mm
- 4 | Supply hose for detergent: 2.500 mm
- 5 | Supply hose for rinse aid: 2.500 mm