



CATALOG OF REPLACEMENT PARTS



MODEL HCM450 CUTTER/MIXER

(INCLUDES MOTOR PARTS)

HCM450	ML-134207
HCM450C	ML-134209

PRIOR MLS COVERED IN THIS MANUAL

HCM450	ML-134170
HCM450C	ML-134172

Table of Contents

Page	Description
3	Miscellaneous
4	Motor and Frame
7	Knife
9	Bowl Lid
10	Control Box (ML-134170 & ML134172)
12	Control Box (ML-134207 & ML-134209)
15	Brake and Bowl
17	Handle Lock
19	Motor

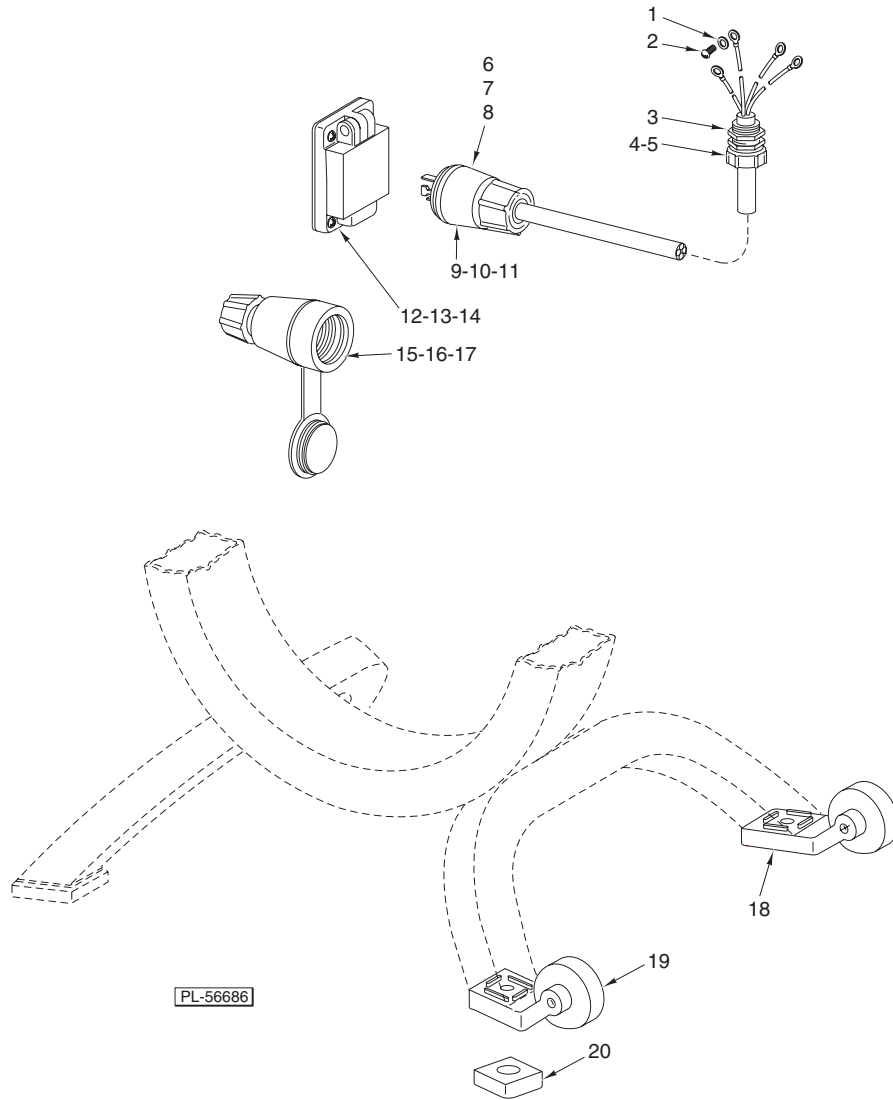

MISCELLANEOUS

ILLUS.	PART NO.	NAME OF PART	AMT.
	PL-56686		
1	WL-007-07	Lockwasher #8 External Shakeproof	1
2	SC-009-56	Mach. Screw 8-32 x 3/8 Slotted Rd. Hd.	1
3	FE-007-12	Lock Nut 3/4 Cnd	1
4	FE-014-14	Strain Relief (60 Hz.)	1
5	FE-015-38	Strain Relief (50 Hz.)	1
6	00-124586	Plug & Cover (200 V.)	1
7	00-117611-00009	Plug - 3 Phase (460 V.)	1
8	00-117611-00008	Plug - 3 Phase (230 V.)	1
9	00-117612-00008	Cord & Plug Assy. (230 V.) (Incls. Item 8)	1
10	00-117612-00009	Cord & Plug Assy. (460 V.) (Incls. Item 7)	1
11	00-122292-00001	Cord & Plug Assy. (200 V.) (Incls. Item 6)	1
12	00-117631-00001	Receptacle (230 V.)	1
13	00-117631-00002	Receptacle (460 V.)	1
14	00-123816-00001	Receptacle & Cover Assy. (200 V.)	1
15	00-117625-00001	Connector (230 V.)	1
16	00-117625-00002	Connector (460 V.)	1
17	00-123805-00001	Connector & Cover Assy. (200 V.) (Not Shown)	1
18	00-123658-00002	Caster Assy. (Right)	1
19	00-123658-00001	Caster Assy. (Left)	1
20	00-123813	Pad - Caster	2
	00-123659	Caster Set (Incls. Items 18, 19, & 20)	1

HCM450 CUTTER/MIXER REPLACEMENT PARTS

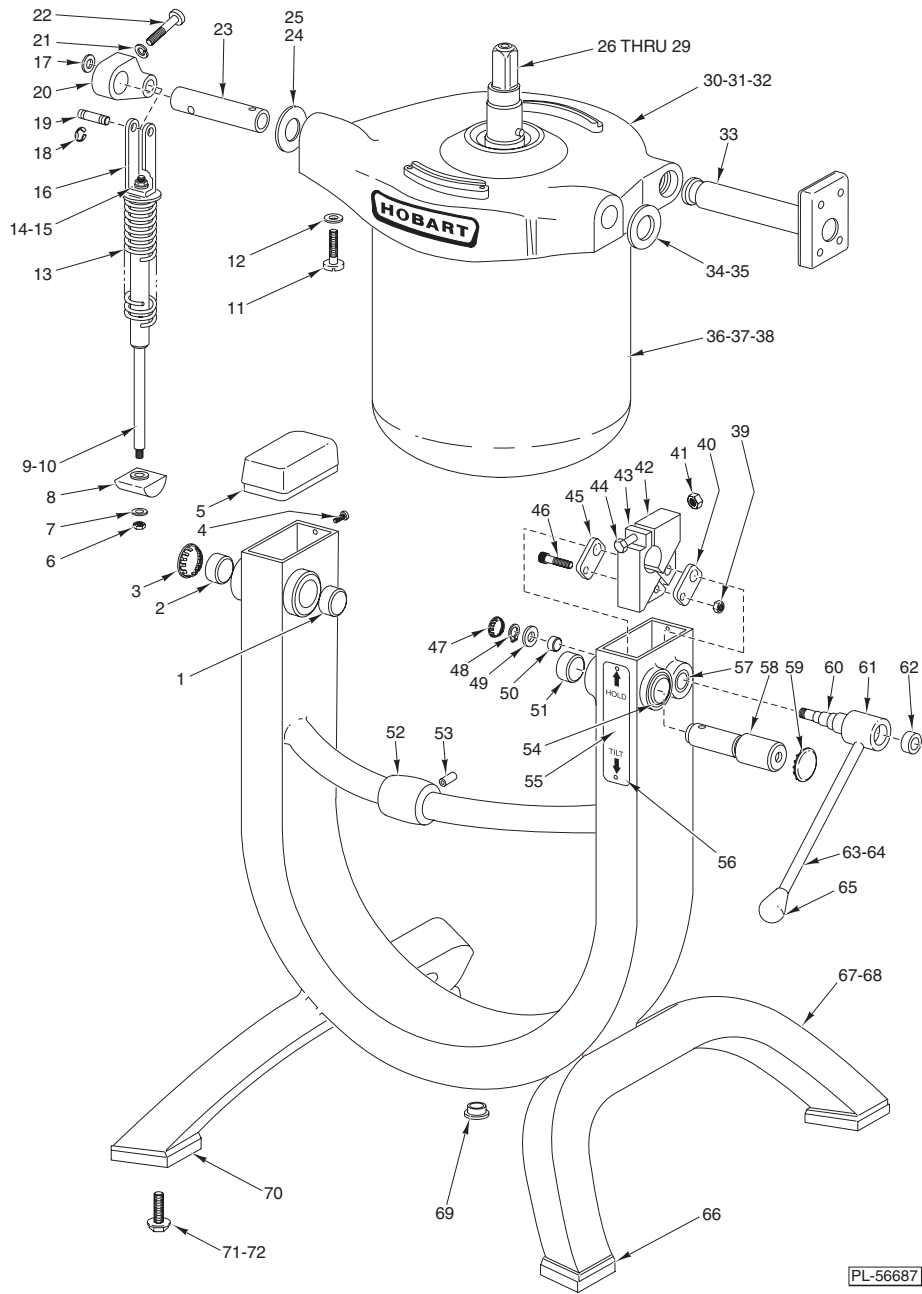

MOTOR AND FRAME

ILLUS.	PART NO.	NAME OF PART	AMT.
	PL-56687		
1	00-108394-00041	Sleeve Bearing (1.25 In. O.D.)	1
2	00-108394-00041	Sleeve Bearing (1.25 In. O.D.)	1
3	PB-004-04	Plug – Button (1 1/4)	1
4	00-123109	Screw – Serrated Head 6-32 x 3/8	4
5	00-122167	Cap – Tube	2
6	NS-031-20	Stop Nut 1/4-20 Elastic	1
7	WS-003-49	Washer	1
8	00-122185	Pivot Pad & Bearing Assy.	1
9	00-122178	Counter Balance Assy. (Incls. Items 6, 7, 8, 10, 13, 14, 15, & 16)	1
10	00-122183	Rod – Spring Guide	1
11	SC-092-62	Cap Screw 3/8-16 x 1 1/2 Soc. Fil. Hd.	2
12	WL-004-06	Lockwasher 3/8 Medium	2

MOTOR AND FRAME (Cont.)

ILLUS.	PART NO.	NAME OF PART	AMT.
PL-56687			
13	00-122184-00001	Spring – Compression	1
14	NS-031-20	Stop Nut 1/4-20 Elastic	1
15	WS-003-49	Washer	1
16	00-122179	Yoke & Spring Guide Assy.	1
17	WS-024-01	Washer	1
18	RR-004-25	Retaining Ring	2
19	00-122189	Shaft – Yoke	1
20	00-122187	Crank & Bearing Assy.	1
21	WL-004-06	Lockwasher 3/8 Medium	1
22	SC-110-08	Cap Screw 3/8-16 x 1 3/4 Hex Soc. Hd.	1
23	00-122177	Shaft – Left Pivot	1
24	00-124740-00001	Spacer – Frame	1
25	00-124740-00002	Spacer – Frame	AR
26	00-122496-00003	Motor Assy. (200/400/60/3) (5 Hp.) (ML-134170 & ML-134172)	1
27	00-122496-00004	Motor Assy. (230/460/60/3) (5 Hp.) (ML-134170 & ML-134172)	1
28	00-122496-00006	Motor Assy. (200/400/60/3) (5 Hp.) (ML-134207 & ML-134209)	1
29	00-122496-00007	Motor Assy. (230/460/60/3) (5 Hp.) (ML-134207 & ML-134209)	1
30	00-122370	Bearing Bracket	1
31	00-117858-00002	Loop Decal	2
32	00-121676-00001	Rivet	4
33	00-122199	Tube & Plate Assy.	1
34	00-124740-00001	Spacer – Frame	1
35	00-124740-00002	Spacer – Frame	AR
36	00-122175-00001	Motor Cover Assy.	1
37	SC-021-91	Mach. Screw 8-32 x 5/16 Slotted Rd. Hd. (SST)	3
38	SC-121-92	Mach. Screw 8-32 x 3/8 Hex Button Hd. (SST) (HCM450C)	3
39	NS-013-14	Nut 5/16 Hex Fin.	1
40	00-122299	Front Link & Bushing Assy.	1
41	NS-032-18	Stop Nut 3/8-16 Flexloc	1
42	00-123560	Clamp Assy. (Right)	1
43	00-122297	Clamp Assy. (Left)	1
44	SC-036-66	Cap Screw 3/8-16 x 3 Hex Hd.	1
45	00-122298	Back Link & Bushing Assy.	1
46	00-122269	Screw – Socket Shoulder	1
47	PB-004-02	Plug Button (1 5/16)	1
48	RR-004-05	Retaining Ring	1
49	WS-029-19	Washer	1
50	00-108394-00037	Sleeve Bearing (0.628 In. O.D.)	1
51	00-108394-00041	Sleeve Bearing (1.25 In. O.D.)	1
52	00-122161	Bumper – Stop (HCM450)	1
53	RP-006-01	Rollpin 3/8 Dia. x 3/4 Lg.	1
54	00-108394-00043	Sleeve Bearing (1.502 In. O.D.)	1
55	00-123610	Label – Hold/Tilt	1
56	00-121676-00001	Screw	2
57	00-108394-00045	Sleeve Bearing (0.878 In. O.D.)	1
58	00-122176	Shaft – Right Pivot	1
59	PB-004-05	Plug Button (1 1/2)	1
60	00-122195	Shaft – Lock	1
61	00-122196	Collar – Shaft	1
62	00-123812	Magnet – Ring	1
63	00-122197	Handle – Lock	1
64	00-477100	Tilt Handle Weldment (HCM450C) (Not Shown)	1
65	00-123173	Knob	1
66	00-122164	Foot (#1)	2
67	00-122151-00001	Frame Assy. (Incls. Items 1, 2, 50, 51, 53, 54, 55, 57, 66, & 70)	1
68	00-122151-00002	Frame Assy. 50 Hz. (Incls. Items 1, 2, 50, 51, 53, 54, 56, 57, 66, & 70)	1
69	00-123772	Plug – Vent	1
70	00-122165	Foot (#2)	2
71	WS-021-09	Washer	4
72	SC-117-97	Cap Screw 1/2-13 x 1 Hex Hd.	4
	00-124361	Feet Set (Incls. Items 70, 72, & 73)	1
	00-122198	Tilt Lock Handle Assy. (Incls. Items 61 thru 64 & 66)	1

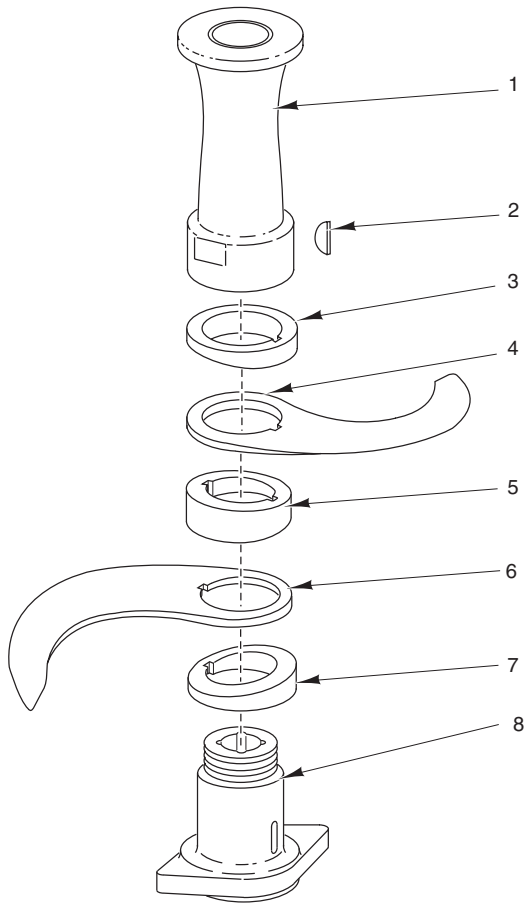

CUT/MIX

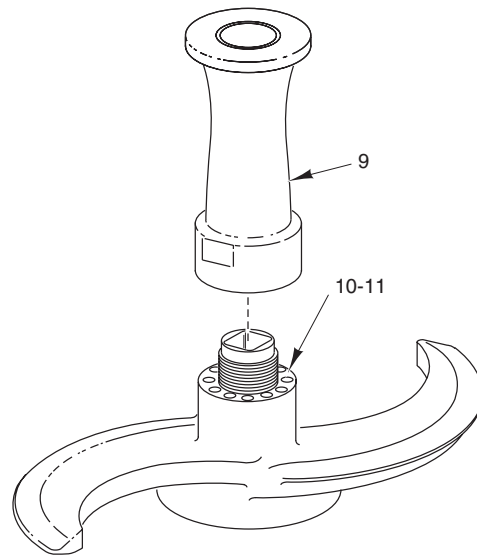

KNEAD/MIX

PL-56688

KNIFE

KNIFE

ILLUS.	PART NO.	NAME OF PART	AMT.
	PL-56688		
1	00-291957	Sleeve – Blade Locking	1
2	KW-004-01	Key #1008 Woodruff	2
3	00-122290	Block – Single Angle	1
4	00-274662	Knife	1
5	00-122291	Block – Double Angle	1
6	00-274662	Knife	1
7	00-122290	Block – Single Angle	1
8	00-124265	Hub – Square Drive	1
9	00-291957	Sleeve – Blade Locking	1
10	00-124647-00001	Blade/Hub – Knead/Mix	1
11	00-124647-00002	Blade/Hub – Knead/Mix (HCM450C)	1
	00-292035-00001	Cut/Mix Shaft Assy. (HCM450) (Incls. Items 1 thru 8)	1
	00-292028	Knead/Mix Blade & Sleeve Assy. (HCM450C) (Incls. Items 9 & 11)	1
	00-292029	Knead/Mix Blade & Sleeve Assy. (HCM450) (Incls Items 9 & 10)	1

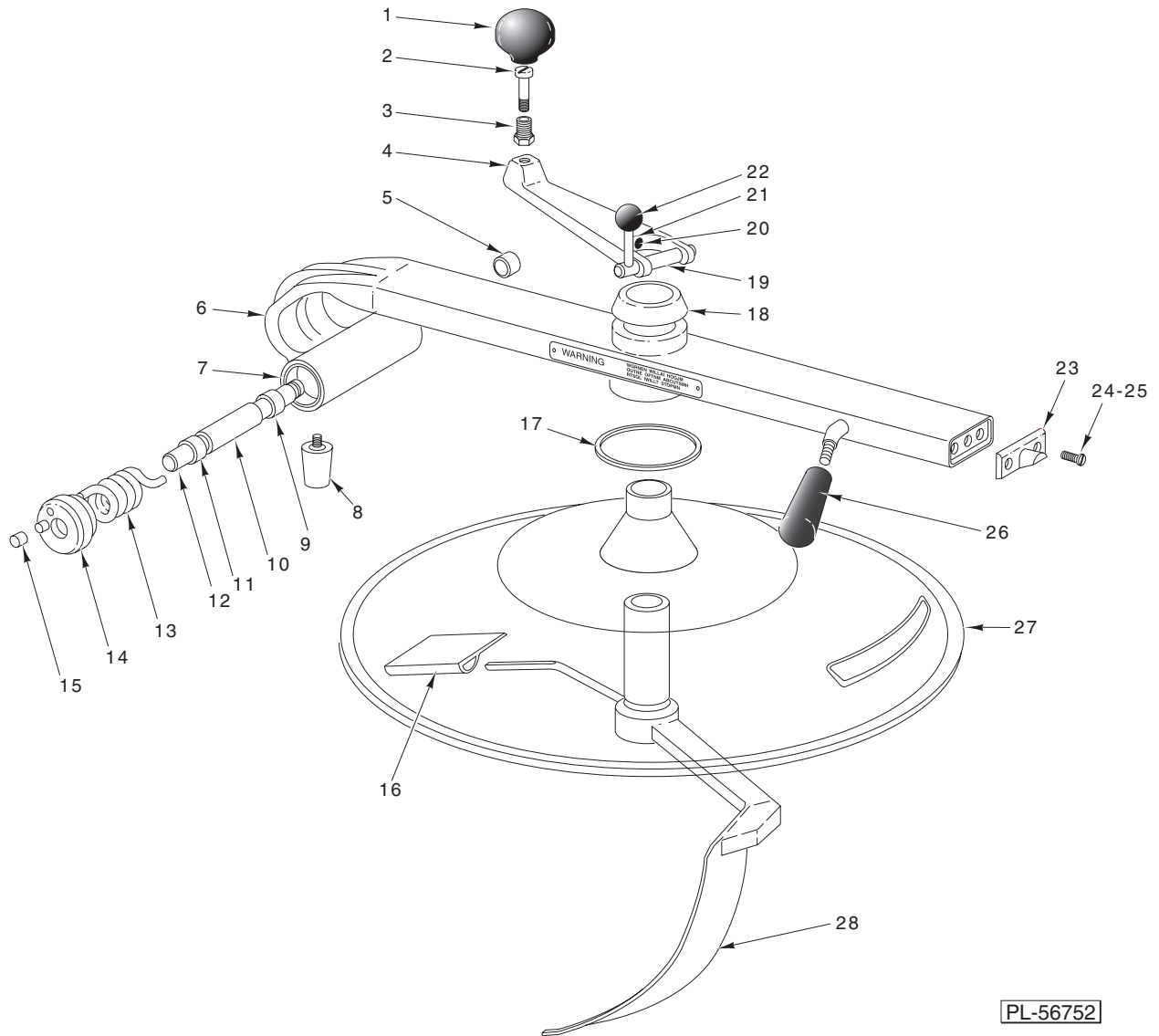

BOWL LID

BOWL LID

ILLUS.	PART NO.	NAME OF PART	AMT.
PL-56752			
1	00-123174	Knob	1
2	00-124356	Stud – Handle	1
3	00-124469	Insert – Handle	1
4	00-123574	Baffle Handle Assy. (Incls. Items 1, 2, 3, & 23 thru 26)	1
5	00-110544-00007	Bushing (0.718 In. O.D.)	1
6	00-290702-00001	Lid Handle Assy. (Incls. Items 5 & 7)	1
7	00-110544-00008	Bushing (1.656 In. O.D.)	1
8	00-122264	Bumper – Lid	1
9	00-108394-00044	Sleeve Bearing (0.878 In. O.D.)	1
10	00-122310	Sleeve	1
11	00-108394-00044	Sleeve Bearing (0.878 In. O.D.)	1
12	00-122265	Shaft – Spring Pivot	1
13	00-122267	Spring – Torsion	1
14	00-123666	Spring – Cap Assy.	1
15	00-290921	Bushing – Lid Spring	1
16	00-122209-00001	Scraper	1
17	00-439991	Shim	1
18	00-122587	Bushing – Cap	1
19	00-122315	Pin – Baffle Lock	1
20	SC-118-52	Set Screw 1/4-20 x 1/2 Hdls., Cup Pt. Long-Loc	1
21	00-122586	Handle – Baffle Lock	1
22	00-077401	Knob	1
23	00-290604	Plate – Lock	1
24	SC-119-58	Mach. Screw 1/4-20 x 1/2 Pan Hd.	2
25	SC-122-52	Mach. Screw 1/4-20 x 3/8 Hex Button Hd. (HMC450C)	2
26	00-123172	Handle	1
27	00-292797	Lid Kit (Incls. Items 17 & 18)	1
28	00-292808	Baffle Bar & Blade Assy.	1
	00-438131-00100	Label – Warning (Rotating Knives)	1

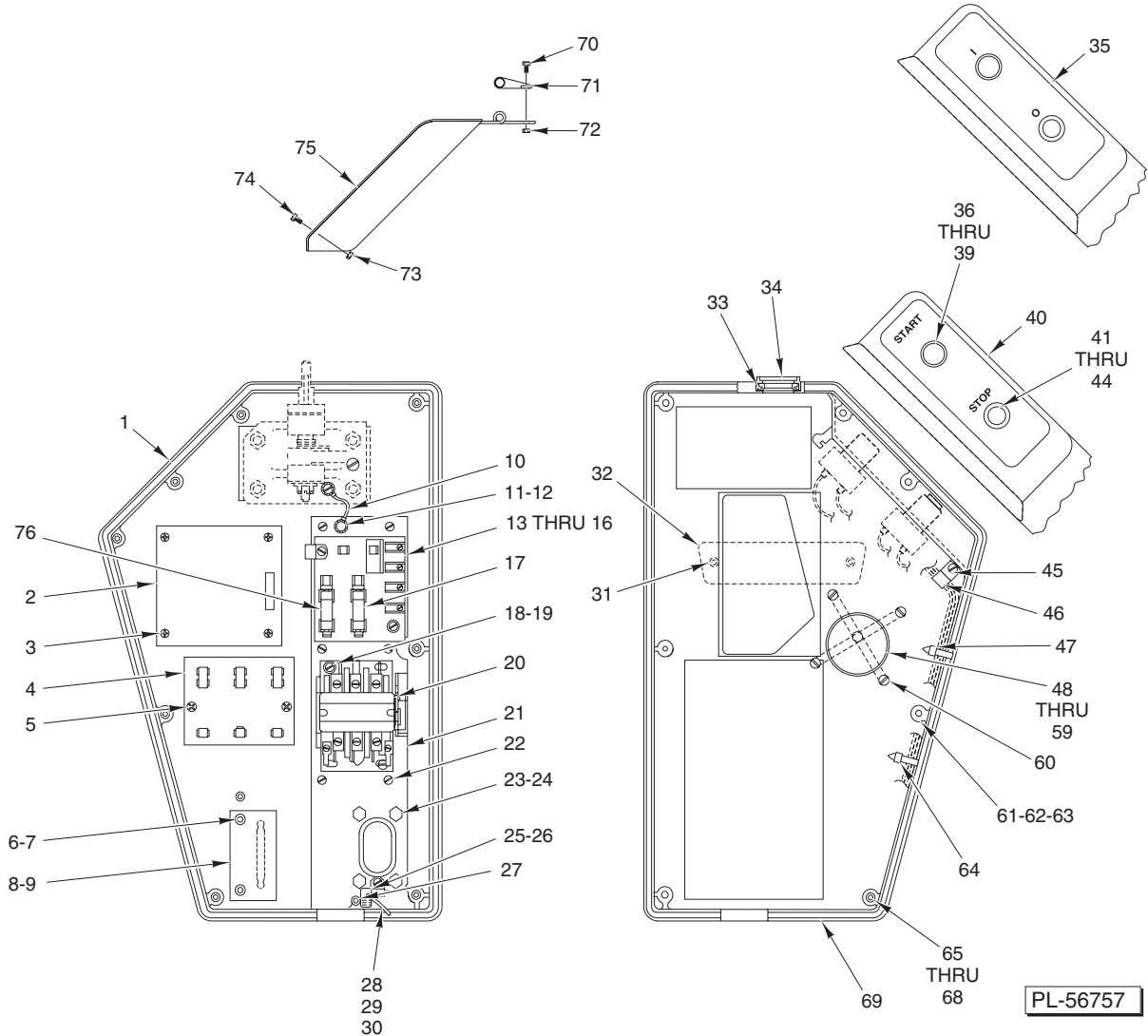

**CONTROL BOX
(ML-134170 & ML-134172)**

ILLUS.	PART NO.	NAME OF PART	AMT.
PL-56757			
1	00-122210	Control Box	1
2	00-278328	Motor Protection Board Assy.	1
3	SD-013-07	Self-Tapping Screw 6-20 x 5/16 Phil. Pan Hd., Type BT	4
4	00-121014	Board – Terminal	1
5	SD-033-05	Self-Tapping Screw 10-16 x 1/2 Slotted Rd. Hd., Type BT	2
6	SD-013-07	Self-Tapping Screw 6-20 x 5/16 Phil. Pan Hd., Type BT	2
7	WS-028-01	Washer	2
8	00-122218	Reed Mounting Board Assy. (Incls. Item 9)	1
9	00-111964	Switch – Reed	1
10	00-123648-00006	Lead Wire Assy. (Ground)	1
11	SC-008-09	Mach. Screw 10-24 x 3/8 Slotted Rd. Hd.	1
12	WL-007-12	Lockwasher #10 External Shakeproof	1
13	00-117034-00007	Power Input Board Assy. (Incls. Items 16 & 17)	1
14	SC-008-09	Mach. Screw 10-24 x 3/8 Slotted Rd. Hd.	3
15	WL-007-12	Lockwasher #10 External Shakeproof	1
16	FE-022-63	Fuse (3 Amp., 125 V.)	1
17	00-294178	Clip – Fuse	2

**CONTROL BOX (Cont.)
(ML-134170 & ML-134172)**

ILLUS.	PART NO.	NAME OF PART	AMT.
18	SC-008-09	Mach. Screw 10-24 x 3/8 Slotted Rd., Hd.	2
19	WL-007-12	Lockwasher #10 External Shakeproof	1
20	00-121926-00002	Contacto r	1
21	00-124042	Control Mounting Bracket Assy.	1
22	SD-033-04	Self-Tapping Screw 10-16 x 3/8 Phil. Rd. Hd., Type BT	6
23	SC-037-85	Cap Screw 5/16-18 x 1 Hex Hd.	4
24	WL-003-47	Lockwasher 5/16 Medium	4
25	00-118234-00005	Cable (5.625 In. Lg.)	1
26	00-118233	Ferrule (Double)	2
27	00-078752-00003	Clamp	1
28	00-122268	Bracket – Cable	1
29	SC-009-69	Mach. Screw 6-32 x 1/2 Slotted Rd. Hd.	1
30	NS-009-07	Mach. Nut 6-32 Hex	1
31	00-121676-00004	Screw – Drive 2 x 3/16 Truss	2
32	00-117858-00002	Logo – Mach. (5 In.)	1
33	00-123074-00005	Seal – V-Ring	1
34	00-123221	Insert – Cover	1
35	00-875480	Label – Start Up W/Pushbuttons (50 Hz.)	1
36	00-087711-322-3	Block – Contact	1
37	00-478752-00001	Switch Assy. (Start)	1
38	00-478753-00002	Cap – Round Pushbutton Flush	1
39	00-873427	Cap – Protective	1
40	00-875475	Label – Start Up W/Pushbuttons (60 Hz.)	1
41	00-087711-322-4	Block – Contact	1
42	00-478752-00002	Switch Assy. (Stop)	1
43	00-478751-00003	Cap – Round Pushbutton Flush	1
44	00-873427-00002	Cap – Protective	1
45	SD-033-03	Self-Tapping Screw 6-20 x 1/2 Slotted Rd. Hd., Type BT	1
46	00-078752-00006	Clamp	2
47	SC-019-34	Mach. Screw 8-32 x 1/2 Slotted Bndg. Hd. (460 V. Only)	2
48	00-294650-004-9	Timer Assy. (200-240/60/3)	1
49	00-294650-004-10	Timer Assy. (380-415/50/3)	1
50	00-294650-004-12	Timer Assy. (460/60/3)	1
51	00-294650-004-13	Timer Assy. (220/50/3)	1
52	00-124826	Guard – Timer Knob (HCM450)	1
53	00-438194	Guard – Timer Knob (HCM450C)	1
54	SC-019-34	Mach. Screw 8-32 x 1/2 Slotted Bndg. Hd.	2
55	WL-007-07	Lockwasher #8 External	2
56	00-292349-00001	Timer Knob Assy. (5 Min. Timer) (60 Hz.)	1
57	00-292349-00002	Timer Knob Assy. (5 Min. Timer) (50 Hz.)	1
58	00-292350	Plate – Indicator	1
59	SC-025-18	Mach. Screw 5-40 x 1/2 Slotted Bndg. Hd. (SST)	2
60	00-113703	Tie – Cable	2
61	00-438239	Insulated Screw Assy. (HCM450C)	3
62	00-290354	Insulated Screw Assy. (HCM450)	5
63	WS-029-20	Washer	4
64	SC-019-34	Mach. Screw 8-32 x 1/2 Slotted Bndg. Hd. (460 V. Only)	2
65	00-067500-00038	O-Ring	1
66	00-438238	Insulated Screw Assy. (HCM450C)	3
67	00-290353	Insulated Screw Assy. (HCM450)	5
68	WS-029-20	Washer	4
69	00-292612	Gasket – Control Box Lid	1
70	SC-121-97	Mach. Screw 10-24 x 3/4 Hex Button Hd. (SST) (HCM450C)	2
71	00-438247	Hasp – Weldment (HCM450C)	1
72	NS-038-13	Lock Nut 10-24 (HCM450C)	2
73	NS-038-13	Lock Nut 10-24 (HCM450C)	2
74	SC-121-97	Mach. Screw 10-24 x 3/4 Hex Button Hd. (SST) (HCM450C)	2
75	00-438242	Cover – Weldment (HCM450C)	1
76	FE-024-16	Fuse 1/2 Amp	2

HCM450 CUTTER/MIXER REPLACEMENT PARTS

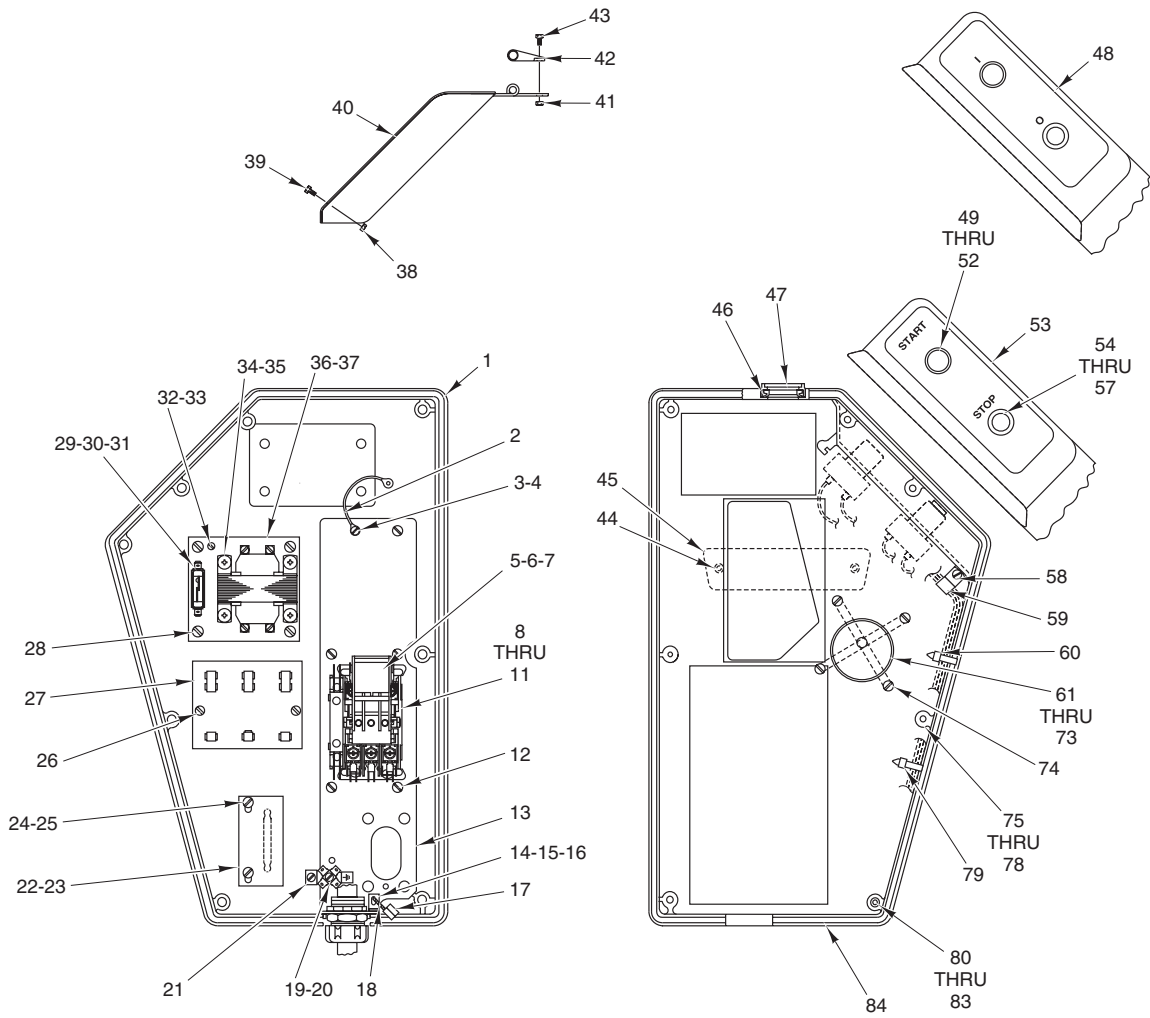

PL-56685

**CONTROL BOX
(ML-134207 & ML-134209)**

ILLUS.	PART NO.	NAME OF PART	AMT.
PL-56685			
1	00-122210	Control Box	1
2	00-123648-00006	Lead Wire Assy. (Ground)	1
3	SC-008-09	Mach. Screw 10-24 x 3/8 Slotted Rd. Hd.	1
4	WL-007-12	Lockwasher #10 External Shakeproof	1
5	00-088196-024-4	Relay - Overload (220/50/3)	1
6	00-088196-024-2	Relay - Overload (380-415/50/3, 460/60/3)	1
7	00-088196-024-1	Relay - Overload (200-208/60/3)	1
8	00-087713-107-1	Contactactor (200-230 V.)	1
9	00-087713-107-2	Contactactor (400-460 V.)	1
10	SC-008-09	Mach. Screw 10-24 x 3/8 Slotted Rd. Hd.	2
11	WL-007-12	Lockwasher #10 External Shakeproof	1
12	SC-033-04	Self-Tapping Screw 10-16 x 3/8 Phil. Rd. Hd., Type BT	6
13	00-124042	Bracket Assy. - Control Mounting	1
14	00-122268	Bracket - Cable	1
15	SC-009-69	Mach. Screw 6-32 x 1/2 Slotted Rd. Hd.	1
16	NS-009-07	Mach. Nut 6-32 Hex	1
17	00-118233	Ferrule (Double)	2
18	00-118234-00005	Cable (5.625 In. Lg.)	1
19	SC-009-61	Mach. Screw 8-32 x 1/2 Slotted Rd. Hd.	1
20	WL-007-07	Lockwasher #8 External Shakeproof	1
21	00-118544-00001	Lug - Solderless (415/50/3)	1

**CONTROL BOX (Cont.)
(ML-134207 & ML-134209)**

ILLUS.	PART NO.	NAME OF PART	AMT.
	PL-56685		
22	00-122218	Board Assy. (3 RMB) (Incls. Item 31)	1
23	00-111964	Switch – Reed	1
24	SD-013-07	Self-Tapping Screw 6-20 x 5/16 Phil. Pan Hd., Type BT	2
25	WS-028-01	Washer	2
26	SD-033-05	Self-Tapping Screw 10-16 x 1/2 Slotted Rd. Hd., Type BT	2
27	00-121014	Board – Terminal	1
28	SD-013-07	Self-Tapping Screw 6-20 x 5/16 Phil. Pan Hd., Type BT	4
29	00-294436-00003	Block – Fuse	1
30	FE-009-25	Fuse (250 V., 0.5 Amp.)	1
31	SD-008-17	Self-Tapping Screw 6-20 x 3/8 Phil. Bndg. Hd., Type B	1
32	SC-008-09	Mach. Screw 10-24 x 3/8 Slotted Rd., Hd.	1
33	WL-007-12	Lockwasher #10 External Shakeproof	1
34	00-101935	Transformer (380-415/50/3, 460/60/3)	1
35	SD-015-20	Self-Tapping Screw 10-32 x 3/8 Phil. Pan Hd., Type TT	4
36	00-875518	Plate Assy. – Transformer Mtg. (380-415/50/3, 460/60/3) (Incls. Items 29 thru 35 & 37)	1
37	00-875513	Plate – Transformer Mounting	1
38	NS-038-13	Lock Nut 10-24 (HCM450C)	2
39	SC-121-97	Mach. Screw 10-24 x 3/4 Hex Button Hd. (HCM450C)	2
40	00-438242	Cover – Weldment (HCM450C)	1
41	NS-038-13	Lock Nut 10-24 (HCM450C)	2
42	00-438247	Hasp – Weldment (HCM450C)	1
43	SC-121-97	Mach. Screw 10-24 x 3/4 Hex Button Hd. (SST) (HCM450C)	2
44	00-121676-00004	Screw – Drive 2 x 3/16 Truss	2
45	00-117858-00002	Logo – Mach. (5 In.)	1
46	00-123074-00005	Seal – V-Ring	1
47	00-123221	Insert – Cover	1
48	00-875480	Label – Start Up W/Pushbuttons (50 Hz.)	1
49	00-087711-322-3	Block – Contact	1
50	00-478752-00001	Switch Assy. (Start)	1
51	00-478753-00002	Cap – Round Pushbutton Flush	1
52	00-873427	Cap – Protective	1
53	00-875475	Label – Start Up W/Pushbuttons (60 Hz.)	1
54	00-087711-322-4	Block – Contact	1
55	00-478752-00002	Switch Assy. (Stop)	1
56	00-478751-00003	Cap – Round Pushbutton Flush	1
57	00-873427-00002	Cap – Protective	1
58	SD-033-03	Self-Tapping Screw 6-20 x 1/2 Slotted Rd. Hd., Type BT	1
59	00-078752-00006	Clamp	2
60	SC-019-34	Mach. Screw 8-32 x 1/2 Slotted Bndg. Hd. (460 V. Only)	2
61	00-294650-004-9	Timer Assy. (200-240/60/3)	1
62	00-294650-04-10	Timer Assy. (380-415/50/3)	1
63	00-294650-04-12	Timer Assy. (460/60/3)	1
64	00-294650-04-13	Timer Assy. (220/50/3)	1
65	00-124826	Guard – Timer Knob (HCM450)	1
66	00-438194	Guard – Timer Knob (HCM450C)	1
67	SC-019-34	Mach. Screw 8-32 x 1/2 Slotted Bndg. Hd.	2
68	WL-007-07	Lockwasher #8 External	2
69	00-067500-00038	O-Ring	2
70	00-292349-00001	Timer Knob Assy. (5 Min. Timer) (60 Hz.)	1
71	00-292349-00002	Timer Knob Assy. (5 Min. Timer) (50 Hz.)	1
72	00-292350	Plate – Indicator	1
73	SC-025-18	Mach. Screw 5-40 x 1/2 Slotted Bndg. Hd. (SST)	2
74	00-113703	Tie – Cable	2
75	00-067500-00038	O-Ring	5
76	00-438239	Insulated Screw Assy. (HCM450C)	5
77	00-290354	Insulated Screw Assy. (HCM450)	5
78	WS-029-20	Washer	5
79	SC-019-34	Mach. Screw 8-32 x 1/2 Slotted Bndg. Hd. (460 V. Only)	2
80	00-067500-00038	O-Ring	3
81	00-438238	Insulated Screw Assy. (HCM450C)	3
82	00-290353	Insulated Screw Assy. (HCM450)	3
83	WS-029-20	Washer	3
84	00-292612	Gasket – Control Box Lid	1
	00-290046	Control Box Lid & Logo Assy. (Incls. Items 45, 46, & 47)	1

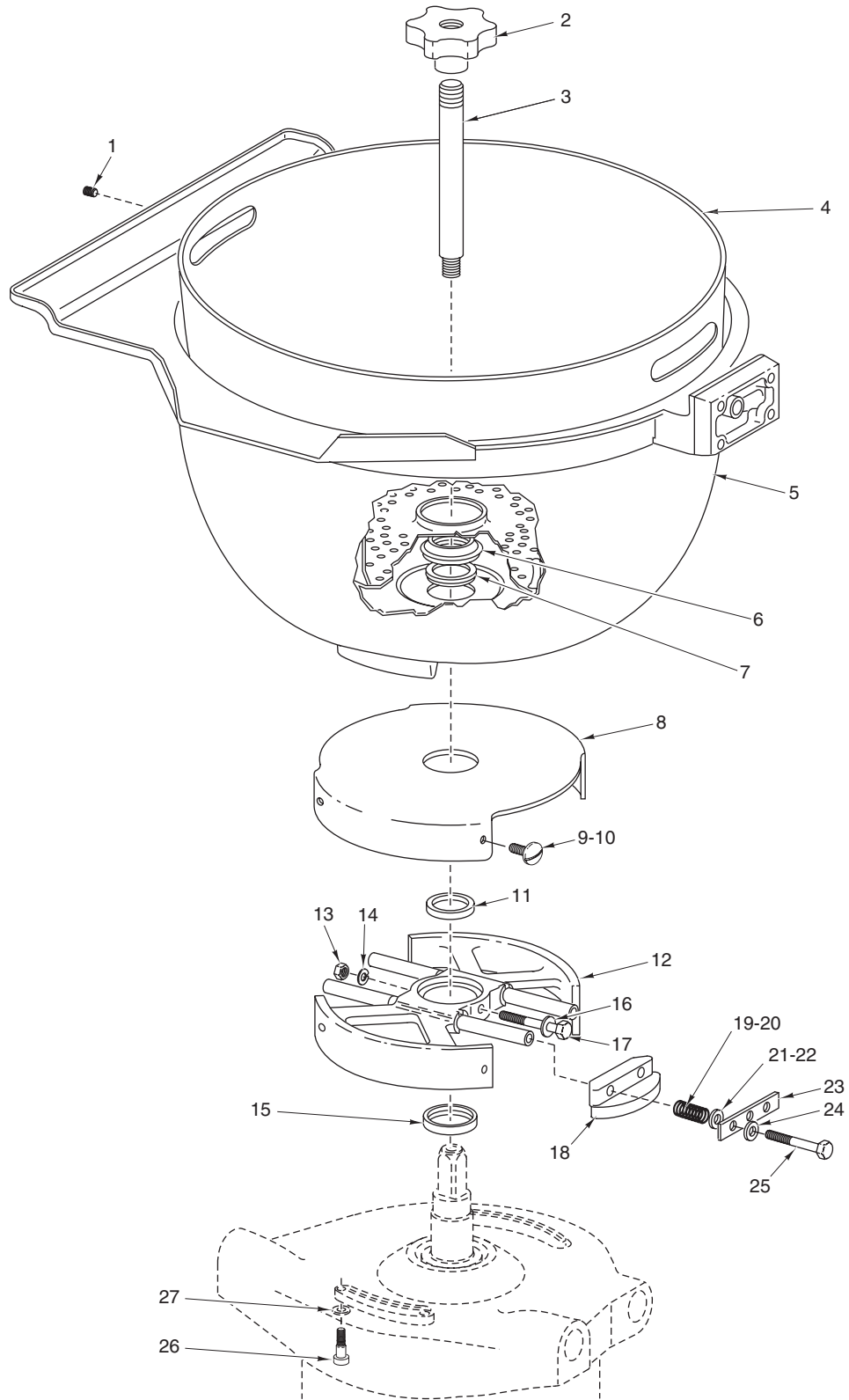

PL-56689

BRAKE AND BOWL

BRAKE AND BOWL

ILLUS. PL-56689	PART NO.	NAME OF PART	AMT.
1	SC-055-01	Set Screw 10-24 x 1/4 Hex Soc. Hdls., Cup Pt. (SST)	1
2	00-291956	Knob – Retainer (Threaded)	1
3	00-274680	Shaft – Extension (Threaded)	1
4	00-292811	Strainer Basket Kit	1
5	00-122245	Bowl Assy.	1
6	00-122313	Retainer – Seal	1
7	00-123920	Seal – V-Ring	1
8	00-291113	Cover – Brake	1
9	SC-109-62	Mach. Screw 10-24 x 3/8 Slotted Pan Hd. (SST)	4
10	SC-121-94	Mach. Screw 10-24 x 3/8 Hex Button Hd. (SST) (HCM450C)	4
11	00-123920	Seal – V-Ring	1
12	00-435526	Brake Carrier Assy.	1
13	NS-013-14	Nut 5/16-18 Hex	1
14	WL-003-47	Lockwasher 5/16 Medium	1
15	00-122523	Seal – Shaft	1
16	WL-008-22	Lockwasher 5/16 Internal Shakeproof	1
17	SC-109-75	Cap Screw 5/16-18 x 2 3/8 Hex Hd.	1
18	00-436472	Brake Shoe & Lining Assy.	2
19	00-123095	Spring – Compression (60 Hz. Motor Only)	4
20	00-124953	Spring – Compression (50 Hz. Motor Only)	4
21	WS-018-30	Washer – Shim (25/64 I.D. x 1/16 Thk.)	AR
22	WS-029-35	Washer – Shim (25/64 I.D. x 1/32 Thk.)	AR
23	00-122170	Plate – Brace	2
24	WS-002-32	Washer (13/64 I.D.)	4
25	SC-110-31	Mach. Screw 10-24 x 3/4 Hex Hd.	4
26	SC-089-35	Cap Screw 3/8-16 x 1 1/4 Soc. Fil. Hd.	4
27	WL-004-06	Lockwasher 3/8 Medium	4

HANDLE LOCK

ILLUS.	PART NO.	NAME OF PART	AMT.
PL-56221			
1	00-290118	Plug – Hole	1
2	NS-036-19	Stop Nut ⁵ / ₁₆ -18 Elastic	1
3	00-290595	Lock Handle Assy.	1
4	00-123221	Insert – Cover	1
5	00-123074-00005	Seal – V-Ring	1
6	SC-097-20	Cap Screw ¹ / ₄ -20 x 1 ¹ / ₈ Hex Hd.	1
7	NS-013-02	Nut ¹ / ₄ -20 Hex Fin.	1
8	NS-013-02	Nut ¹ / ₄ -20 Hex Fin.	1
9	00-290913	Stud	4
10	WL-003-47	Lockwasher ⁵ / ₁₆ Medium	4
11	NS-013-14	Nut ⁵ / ₁₆ -18 Hex Fin.	4
12	WL-004-40	Lockwasher #10 Medium	2
13	SC-008-09	Mach. Screw 10-24 x ³ / ₈ Slotted Rd. Hd.	2
14	00-087711-154-1	Switch – Interlock	1
15	00-290059	Insulator	1
16	SC-081-05	Mach. Screw 4-40 x ³ / ₄ Slotted Rd. Hd.	2
17	WL-003-03	Lockwasher #4 Medium	2
18	NS-009-45	Mach. Nut 4-40 Hex	2
19	00-124968	Bracket – Switch	1
*20	00-290606	Lock Shaft Assy.	1
21	00-123173	Knob	1
22	00-477102	Lock Handle Weldment (Not Shown) (HCM450C)	1

*This Assembly is Spring Loaded. Do Not Disassemble.

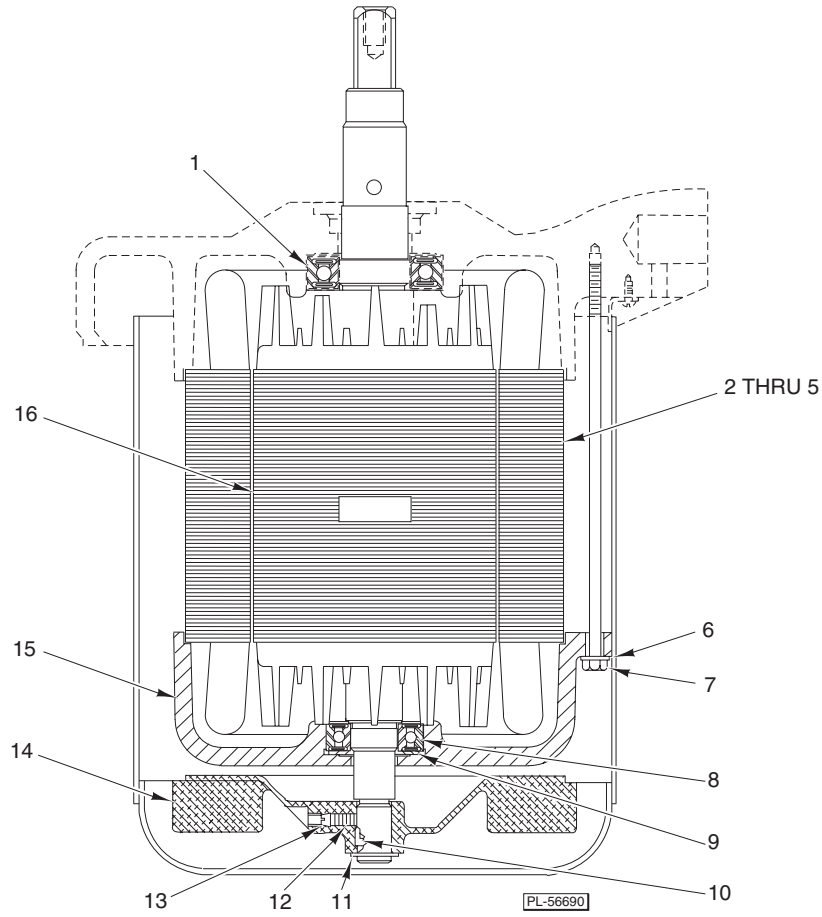

MOTOR

MOTOR

ILLUS.	PART NO.	NAME OF PART	AMT.
PL-56690			
1	BB-021-03	Ball Bearing #MRC207SZZ	1
2	00-065478-137-1	Stator Assy. (200/400/60/3) (5 Hp.) (ML-134170 & ML134172)	1
3	00-065478-137-2	Stator Assy. (230/460/60/3) (5 Hp.) (ML-134170 & ML134172)	1
4	00-065478-137-3	Stator Assy. (200/400/60/3) (5 Hp.) (ML-134207 & ML-134209)	1
5	00-065478-137-4	Stator Assy. (230/460/50/60/3) (5 Hp.) (ML-134207 & ML-134209)	1
6	WL-003-47	Lockwasher ⁵ / ₁₆ Medium	3
7	00-122531-00001	Bolt – Special (5 Hp.)	3
8	BB-021-02	Ball Bearing – Fafnir #P205KDD	1
9	SL-005-01	Loading Spring – N.D. #52 Wavy	2
10	00-012430-00052	Key	1
11	RR-011-03	Retaining Ring	1
12	SC-075-11	Set Screw ¹ / ₄ -20 x ⁵ / ₈ Soc. Hdls., Kn. Cup Pt.	1
13	SC-117-59	Set Screw ¹ / ₄ -20 x ¹ / ₈ Soc. Hdls., Flat Pt.	1
14	00-275183	Fan	1
15	00-122392	Bracket – Bearing	1
16	00-015747-00298	Rotor Assy. (5 Hp.)	1

