

AW = drain water (CNS)	KW = cold water	üOKFF = above finished floor
Dat = dataline	KWw = cold water soft	UK = lower edge
EZ = power line 230V / 400V	LR = conduit Ø	VEW = demineralized water
FD = floor opening	CNS = stainless steel (inox)	WD = wall opening
HW-VL = hot water flow	MK = supply channell	WS = wall slot
HW-RL = hot water return	PE = equipotential conductor	WW = warm water
KB = cored hole Ø	STL = control line	WWw = warm water soft

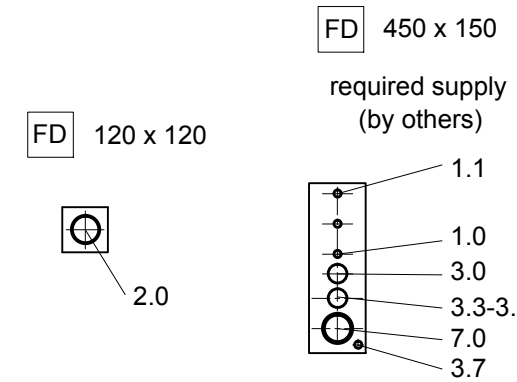

Installation: All installations should always comply with all national and local codes of practice.
Exhaust: A frost-protection flap is recommended if the exhaust air from the machine is exterior ducted.
Transport: Minimum measurements of entry doors for machine assembly = outer measurements of largest machine + 300mm in height, + 400mm in width!
Aeration: The ventilation and exhaust for the room must be interpreted according to local by-laws.
Shut-off valves: The shut-off valves for rinsewater, tankfilling or demi-rinse are supplied by others.
Control- and datalines: We recommend a conduit for control-lines in the area of the electrical connection.
Washing result: A spotless cleaning results can be achieved only with low mineral content of the rinse water. We recommend a conductance of about 80µS/cm.
Floor drain: Splash floor drains should be provided for general cleaning purposes.

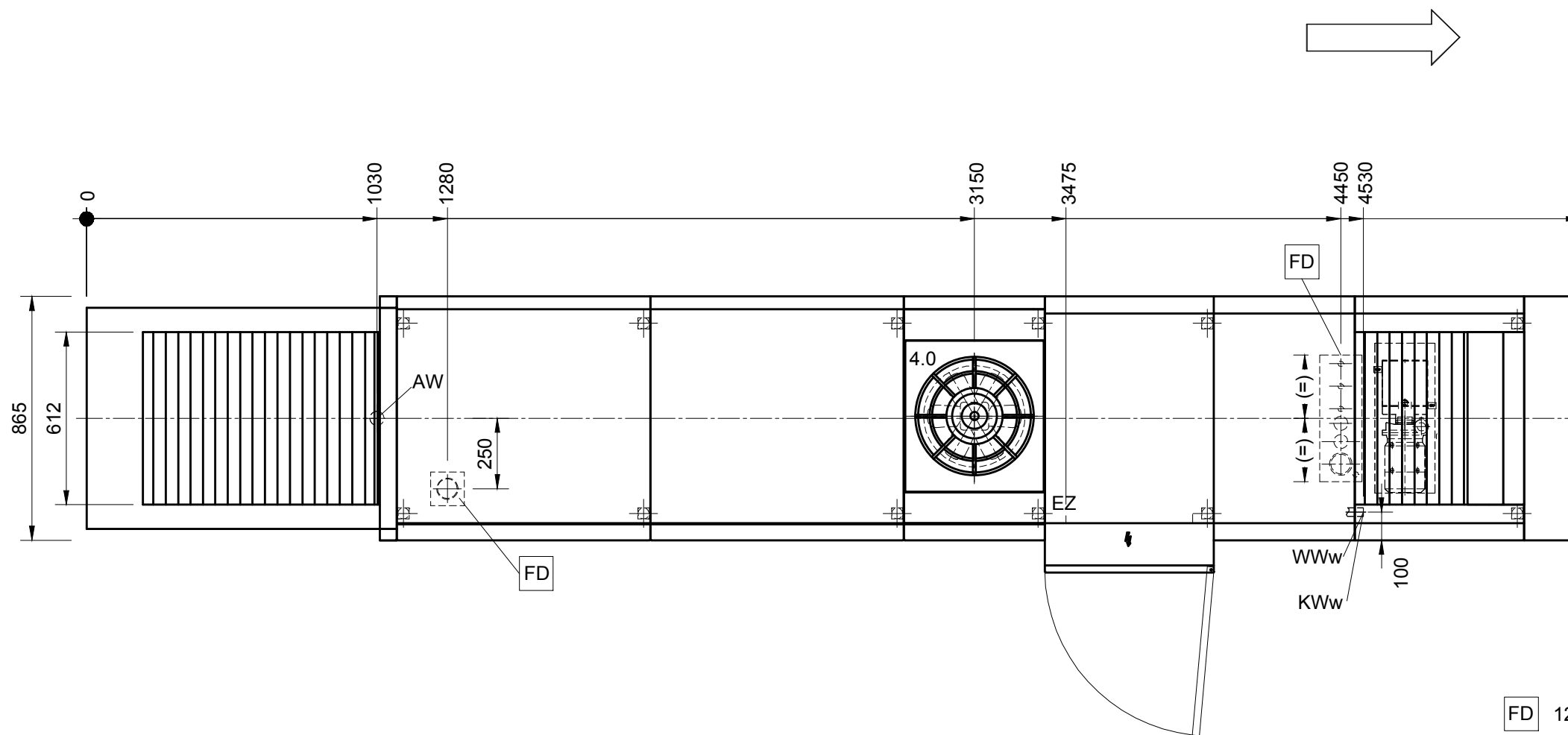
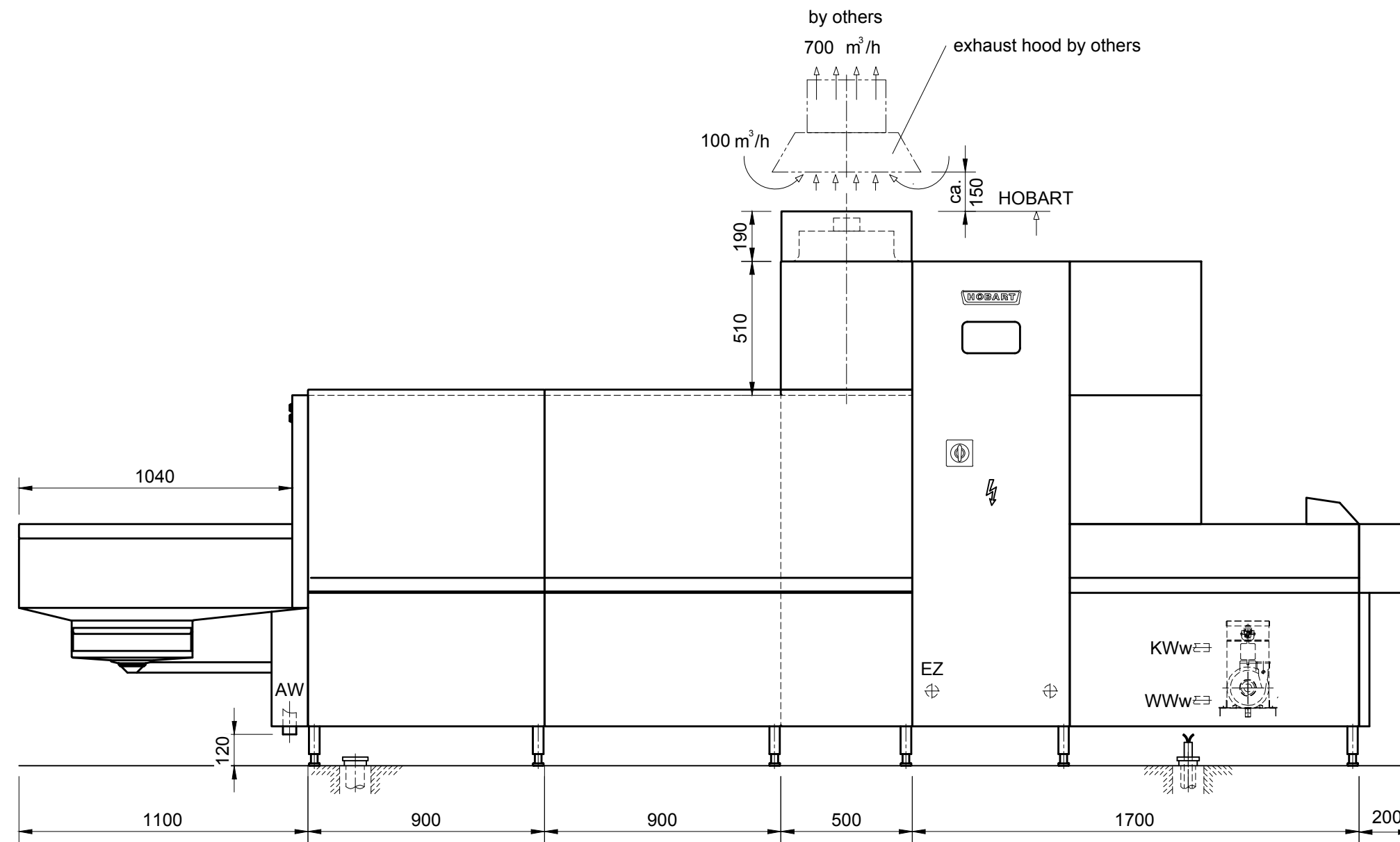
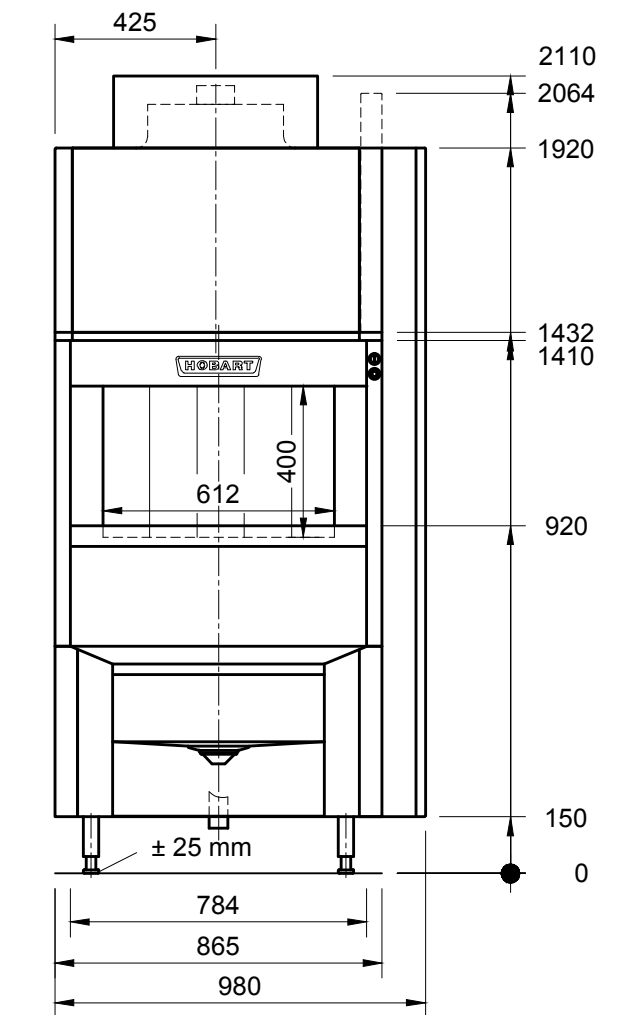

Machine-Type:	Flight-Type Dishwasher	Heating: Electrical
Model:	PROFI FTN 2-L-A-DL3, C25	Operation: Left / Right
Usable-Width: 612	Usable-Height: 400	Main-Switch: Built in Machine

Chemical	conduit for chemical supply				Dimension	Position in mm	
7.0					Ø70	100mm AFFL	
Exhaust	Volume	Temp.	Humidity	Pressure	Dimension	Position in mm	
4.0	600 m³/h	32°C	90-98%	ca. 0 Pa	Ø300 internal	refer to drawing	
Electrical	Control and Data-Line				Extended-Length		
3.7	Equipotential				min. 1x6mm² provided by customer	3m reserve	
3.5	Malfunction-Sensor				5x1.5 mm²	STL 3m reserve	
3.4	Exhaust				3x1.5 mm²	STL 3m reserve	
3.3	Dosage-System				7x1.5 mm²	STL 3m reserve	
Electrical	Voltage	Frequency	Supply	Fuse	Cross-Section	Power	Extended-Length
3.0	400 V	50 HZ	3-PE	3xØ A	4x25 mm²	42.4 kW	EZ 3m reserve
Water	Consumption	Temp.	Hardness	Conductance	Dimension	Connection	Position in mm
2.0					Ø70	Drain pipe	50 mm AFFL
1.1	WWw 264 l (Filling)	50-60 °C	max. 8.75 clark (1.2mmol/l)	150-400µS/cm	Ø20	G3/4" male	100mm AFFL
1.0	KWw 180 l/h	12 °C	max. 3.75 clark (0.5mmol/l)	80-120µS/cm	Ø20	G3/4" male	100mm AFFL

Water-Flow-Pressure provided by customer min. 1.5 bar / 22 psi			
Heat-Radiation (thermal output to the room)			
washware	7.7 kW	latent	2.0 kW
		sensible	4.1 kW

Das Urheberrecht an dieser Zeichnung verbleibt bei der HOBART GmbH.
 Jede nicht von uns schriftlich genehmigte Benutzung, Verfielßigung, Überlassung an Dritte ist strafbar und macht schadensersatzpflichtig.
 This document contains proprietary and confidential data of HOBART GmbH. No disclosure, reproduction or use of any part thereof may be made without written permission of HOBART GmbH.

HOBART HOBART GmbH - Robert-Bosch-Straße17 - 77656 Offenburg, Germany
 Tel.: +49(0)781.600-0 - Fax.: +49(0)781.600-2319 - www.hobart.de

Angebot Quotation
 Bestellung Order

Datum / Date: 02.11.2011	Project:		
Gezeichnet / Drawn by: R.Leonhardt			
Geprüft / Checked by: R.H.	Maßstab / Scale: 1:20	Order-No.:	Zeichnungsnummer / Drawing-No.: FTN EF 6x4 2-L-A-DL3, C25 LR
Projectmanager: XXXX			