

VULCAN CATALOG OF REPLACEMENT PARTS

EV SERIES ELECTRIC RESTAURANT RANGES

MODEL

<i>EV12</i>	<i>ML-137304</i>
<i>EV24S</i>	<i>ML-137290</i>
<i>EV36S</i>	<i>ML-137303</i>
<i>EV60SS</i>	<i>ML-137295</i>



For additional information on Vulcan-Hart Company or to locate an authorized parts and service provider in your area, visit our website at www.vulcanequipment.com

TABLE OF CONTENTS

3	OVEN CONTROLS (ML-137295 & ML-137303)
4	PLATES
5	ELECTRICAL COMPONENTS (ML-137290 & ML-137295)
6	ELECTRICAL COMPONENTS (ML-137303)
7	CONTROLS AND ELECTRICAL COMPONENTS (ML-137304)
8	OVEN AND RANGE CONTROLS (ML-137290)
9	RANGE CONTROLS (ML-137295 & ML-137303)
11	BODY (ML-137304)
13	BODY (ML-137290, ML-137295, & ML-137303)
15	DOOR (ML-137290, ML-137295, & ML-137303)
17	RANGE TOP ELEMENTS
18	OVEN ELEMENTS (ML-137290, ML-137295, & ML-137303)
19	OVEN RACKS (ML-137290, ML-137295, & ML-137303)
21	REINFORCED SHELF
22	WIRING DIAGRAMS
23	WIRING DIAGRAMS
24	WIRING DIAGRAMS
25	WIRING DIAGRAMS
26	WIRING DIAGRAMS
27	WIRING DIAGRAMS
28	WIRING DIAGRAMS

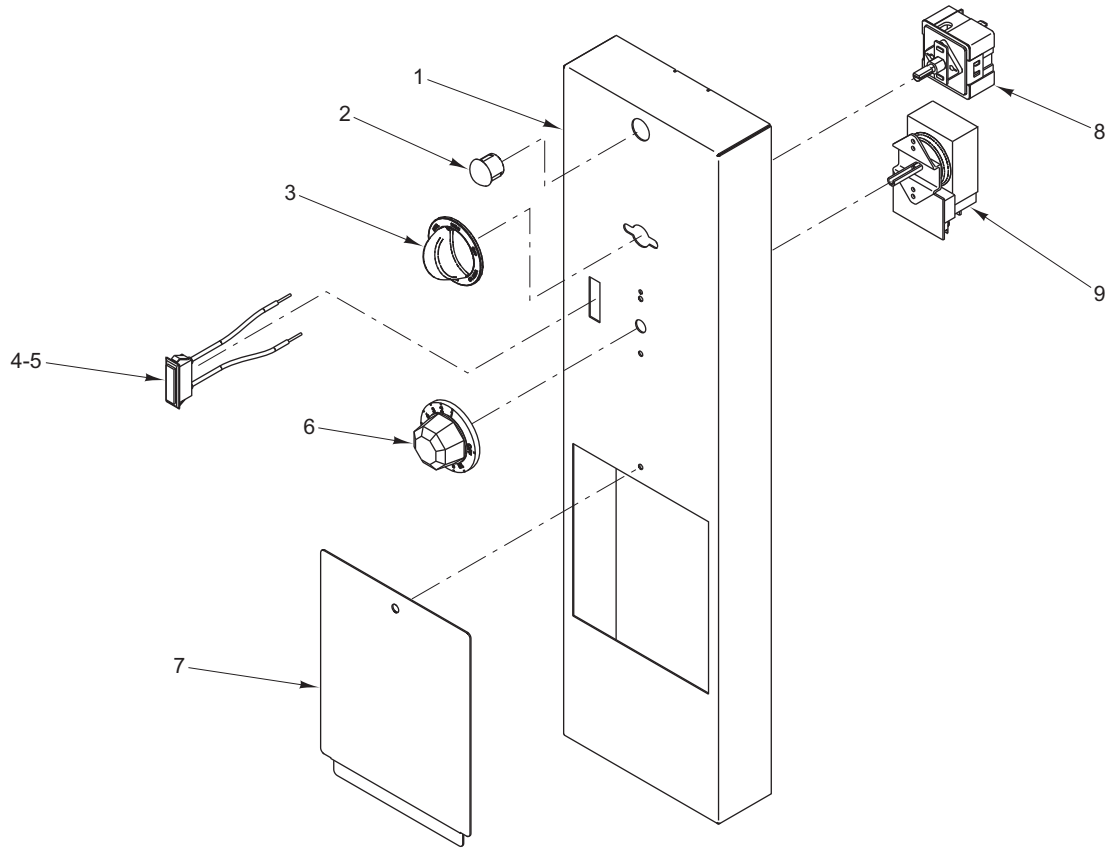

PL-59466

OVEN CONTROLS (ML-137295 & ML-137303)

ILLUS.	PART NO.	NAME OF PART	AMT.
PL-59466			
1	00-927506	Control Panel – Vulcan	AR
2	00-928068-00001	Plug.....	1
3	00-412251-00001	Knob – Infinite Switch (Not Required On 480 V. Units).....	AR
4	00-428900-000G3	Light – Indicator	AR
5	00-417876-00001	Resistor (300 K., 1/4 W.) (480 V. Units).....	1
6	00-418060-00002	Dial – Thermostat.....	AR
7	00-927507	Door – Access.....	AR
8	00-411503-00004	Switch – Infinite Load Control (Not Required On 480 V. Units)	AR
9	00-411506-00014	Thermostat (175-550 F.)	AR
	00-927533-0000G1	Harness – Main (LH).....	1
	00-927541-0000G1	Harness – Power	1

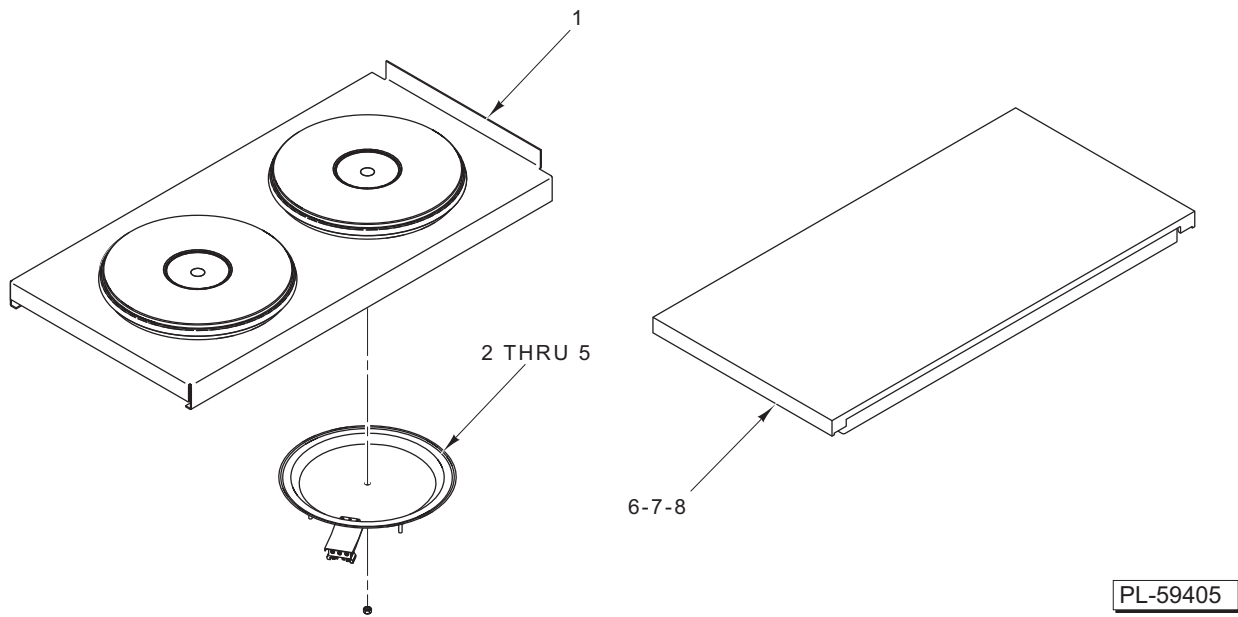

PLATES

ILLUS.	PART NO.	NAME OF PART	AMT.
PL-59405			
1	00-927501-0000A	Plate – Aeration (French Plate).....	AR
2	00-421240-00001	Plate – French E.G.O. (208 V.).....	AR
3	00-421240-00002	Plate – French E.G.O. (240 V.).....	AR
4	00-421240-00003	Plate – French E.G.O. (480 V.).....	AR
5	00-415048-00001	Clamp.....	AR
6	00-421320-00001	Top – Hot (208 V.).....	AR
7	00-421320-00002	Top – Hot (240 V.).....	AR
8	00-421320-00003	Top – Hot (480 V.).....	AR
	00-497042-000G2	French Plate (208/240 V.).....	AR
	00-927601-000G1	Harness – French Plate (36 In.) (208/240 V.).....	AR
	00-927601-000G2	Harness – French Plate (36 In.) (480 V.).....	AR

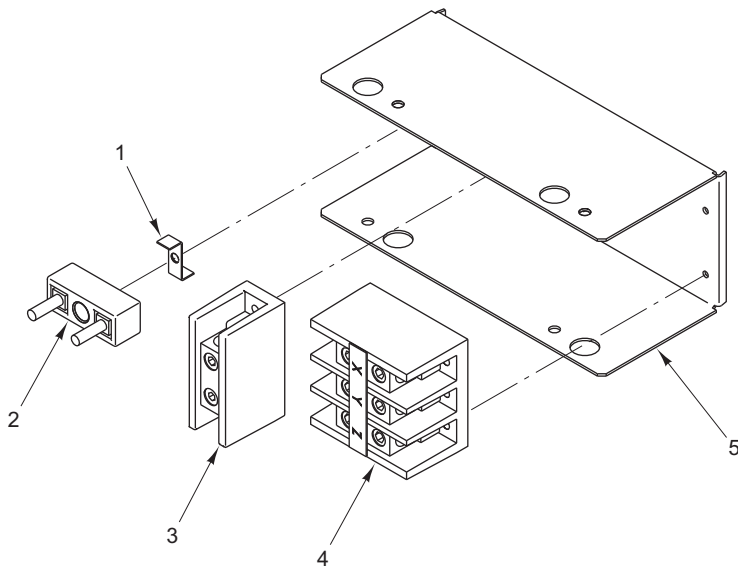

PL-59409

ELECTRICAL COMPONENTS (ML-137290 & ML-137295)

ILLUS.	PART NO.	NAME OF PART	AMT.
PL-59409			
1	00-497218-00001	Clip – Porcelain	1
2	00-414881-00001	Block – Porcelain	1
3	00-410472-00009	Block – Terminal (1-Pole)	1
4	00-410472-00008	Block – Terminal (3-Pole)	1
5	00-927514	Holder – Terminal Blocks	1

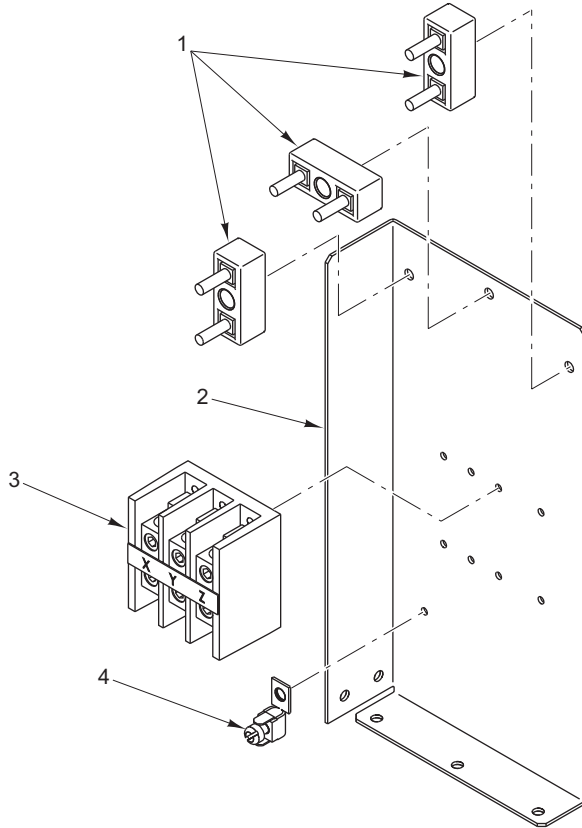

PL-59467

ELECTRICAL COMPONENTS (ML-137303)

ILLUS.	PART NO.	NAME OF PART	AMT.
PL-59467			
1	00-414881-00001	Block – Porcelain	3
2	00-927509	Bracket – Terminal Block Mount	1
3	00-410472-00008	Block – Terminal (3-Pole).....	1
4	00-417856-00001	Lug – Ground (With Set Screw).....	1

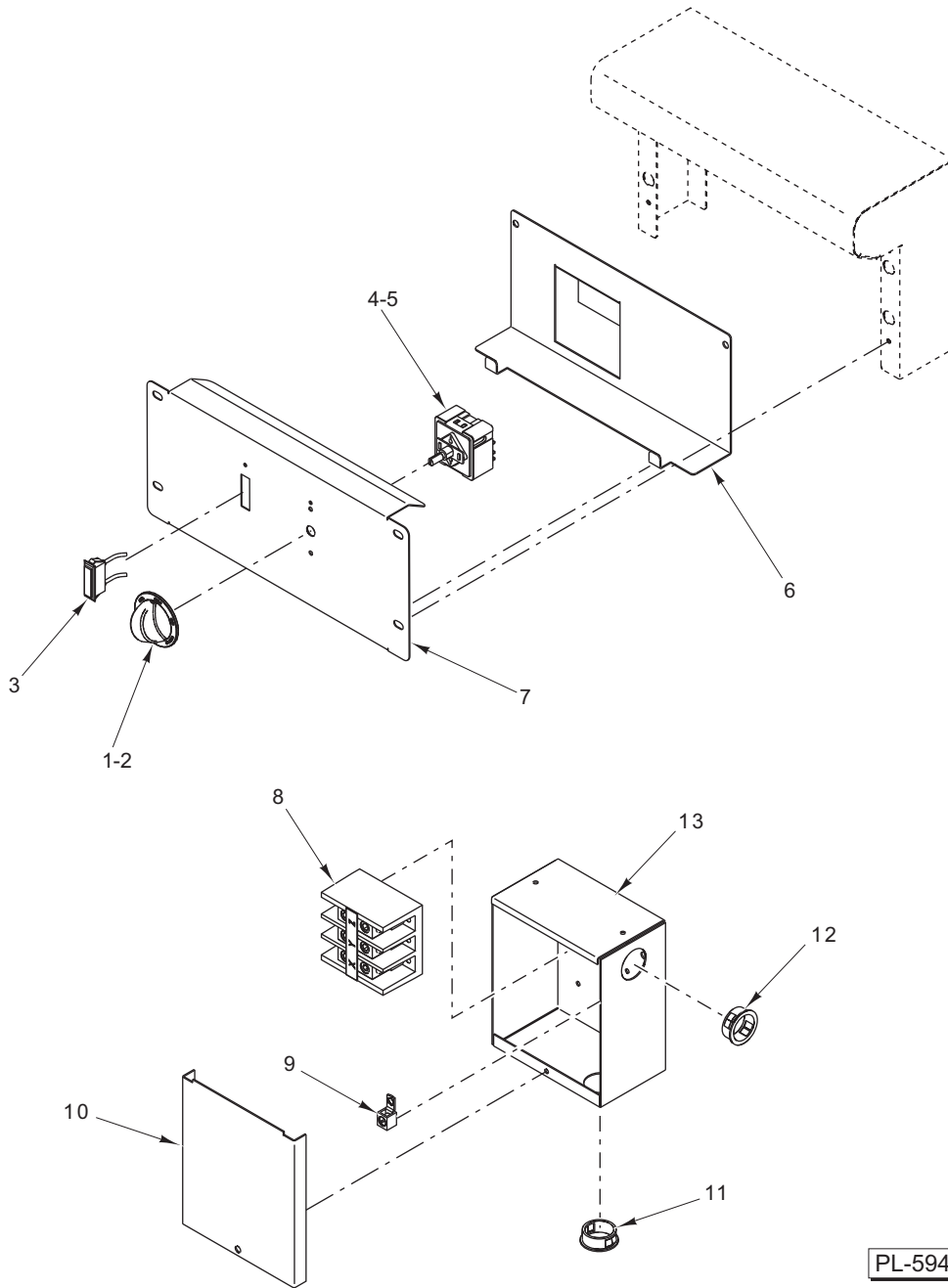

PL-59410

CONTROLS AND ELECTRICAL COMPONENTS (ML-137304)

ILLUS.	PART NO.	NAME OF PART	AMT.
PL-59410			
1	00-412251-00001	Knob – Infinite Switch (208/240 V.).....	1
2	00-412251-00003	Knob – Electric (480 V.).....	1
3	00-499974-00001	Plug – Light.....	1
4	00-411503-00004	Switch – Infinite Load Control (208/240 V.).....	1
5	00-355798-00001	Switch – 4-Position Range (480 V.).....	1
6	00-927455	Bracket – Mount.....	1
7	00-497495	Cover – Manifold.....	1
8	00-410472-00008	Block – Terminal (3-Pole).....	1
9	00-417856-00001	Lug – Ground (With Set Screw).....	1
10	00-499076	Lid – Power Supply.....	1
11	FE-017-16	Bushing – Electrical Snap.....	1
12	FE-017-16	Bushing – Electrical Snap.....	1
13	00-499075	Box – Main Power.....	1

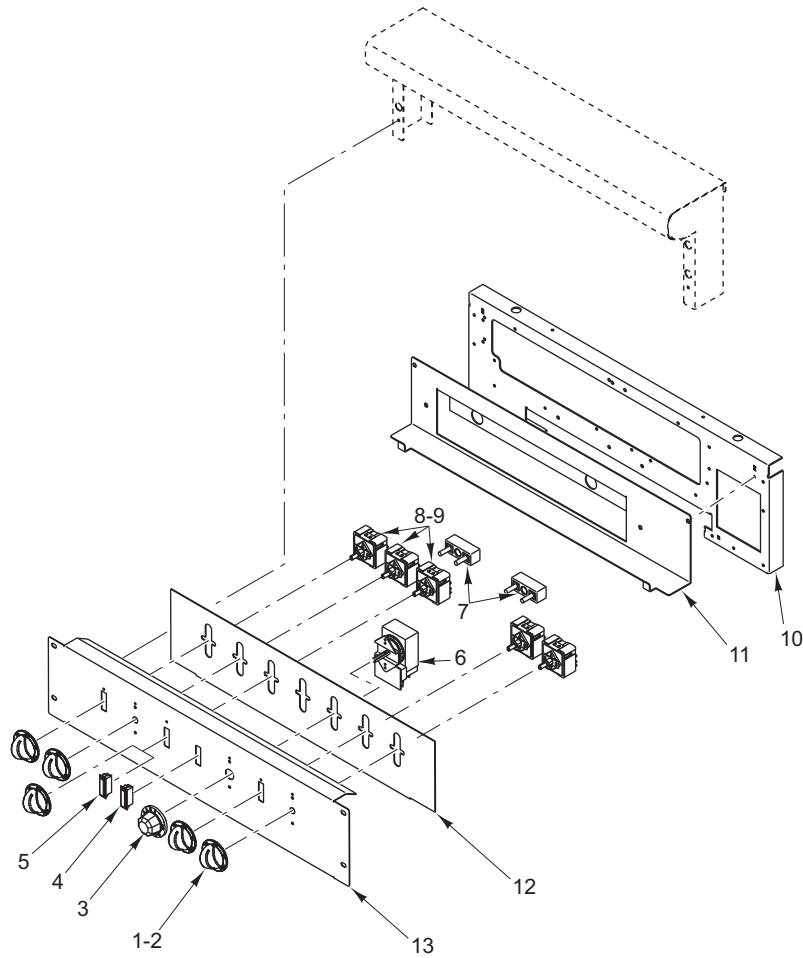

PL-59472

OVEN AND RANGE CONTROLS (ML-137290)

ILLUS.	PART NO.	NAME OF PART	AMT.
1	00-412251-00001	Knob – Infinite Switch	AR
2	00-412251-00003	Knob – Electric (480 V.)	AR
3	00-418060-00002	Dial – Thermostat.....	AR
4	00-499974-00001	Plug – Light (480 V.)	AR
5	00-499974-00001	Plug – Light (480 V.)	AR
6	00-411506-00014	Thermostat (175-550 F.)	AR
7	00-414881-00001	Block – Porcelain	AR
8	00-411503-00004	Switch – Infinite (208/240 V.)	AR
9	00-355798-00001	Switch – 4-Position Range (480 V.)	AR
10	00-924502-0000A	Frame Assy. – Top	1
11	00-927406	Bracket – Mount.....	1
12	00-927408	Panel – Stiffener	1
13	00-927519	Cover	1

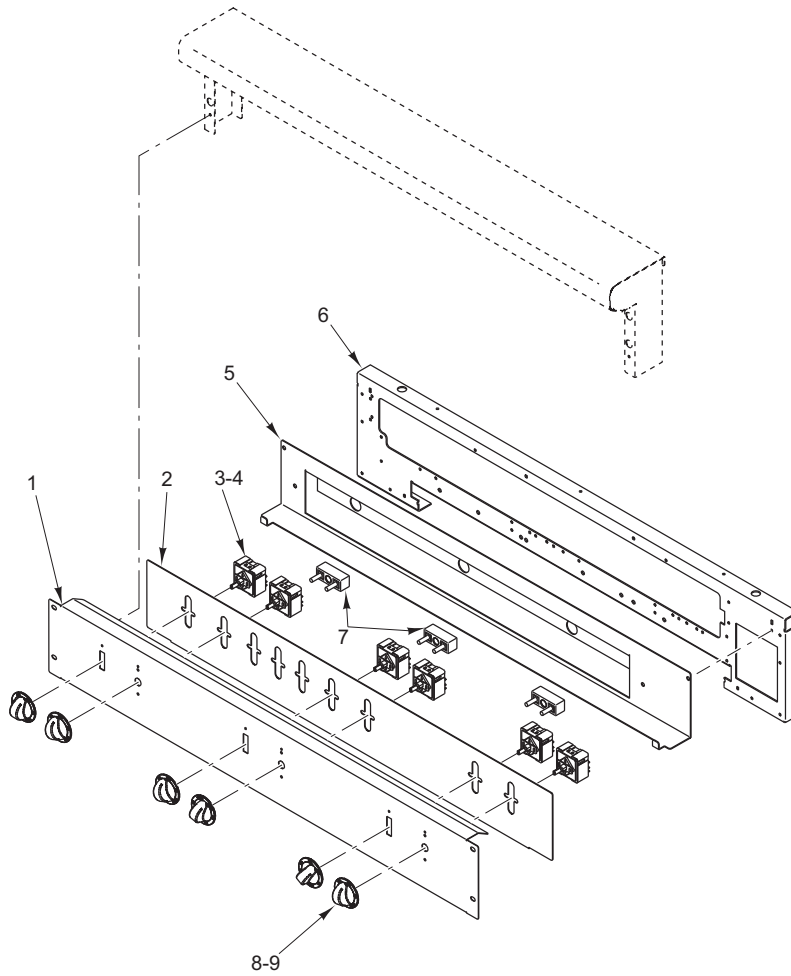

PL-59411

RANGE CONTROLS (ML-137295 & ML-137303)

ILLUS.	PART NO.	NAME OF PART	AMT.
PL-59411			
1	00-927502	Cover	1
2	00-927503	Panel – Stiffener	1
3	00-411503-00004	Switch – Infinite (208/240 V.)	AR
4	00-355798-00001	Switch – 4-Position Range (480 V.)	AR
5	00-927498	Bracket – Mount.....	1
6	00-925003-0000A	Frame Assy. – Top	1
7	00-417934	Block	AR
8	00-412251-00001	Knob – Infinite Switch	AR
9	00-412251-00003	Knob – Electric (480 V.)	AR

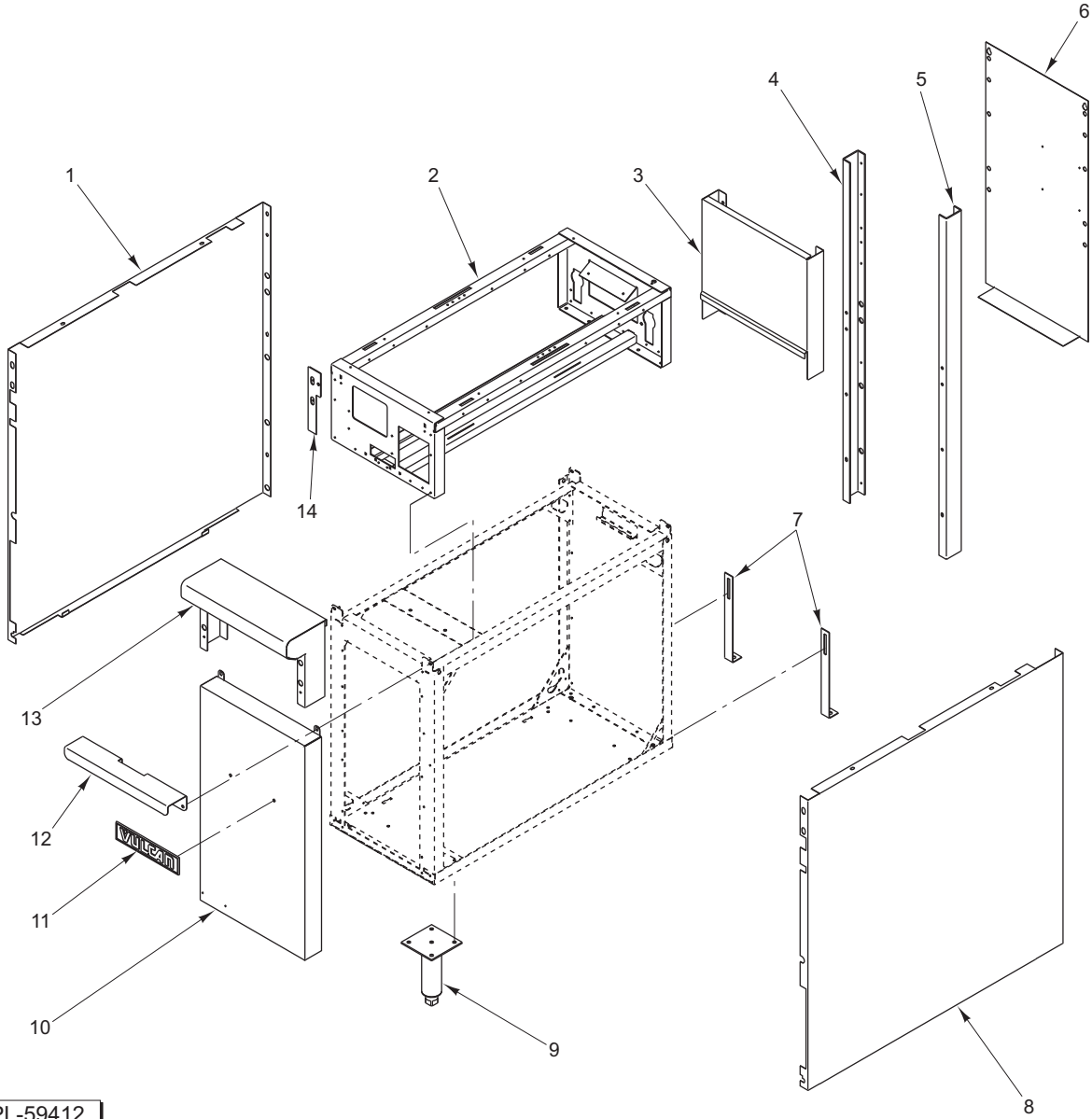

PL-59412

BODY (ML-137304)

BODY (ML-137304)

ILLUS.	PART NO.	NAME OF PART	AMT.
PL-59412			
1	00-921048	Panel – Side (LH)	1
2	00-924002-0000A	Frame Assy.	1
3	00-921314	Panel – Backsplash	1
4	00-921133	Channel	1
5	00-921134	Channel	1
6	00-927460	Heat Shield – Rear	1
7	00-927459	Bracket – Anchor	2
8	00-921047	Panel – Side (RH)	1
9	00-413112-00012	Leg (6 In.) (SST)	4
10	00-927464	Cover – Front	1
11	00-928020	Nameplate – Vulcan (10 In.)	1
12	00-927462	Handle – Crumb Tray	1
13	00-921017-0000A	Bullnose	1
14	00-921058	Gasket – Bullnose	2

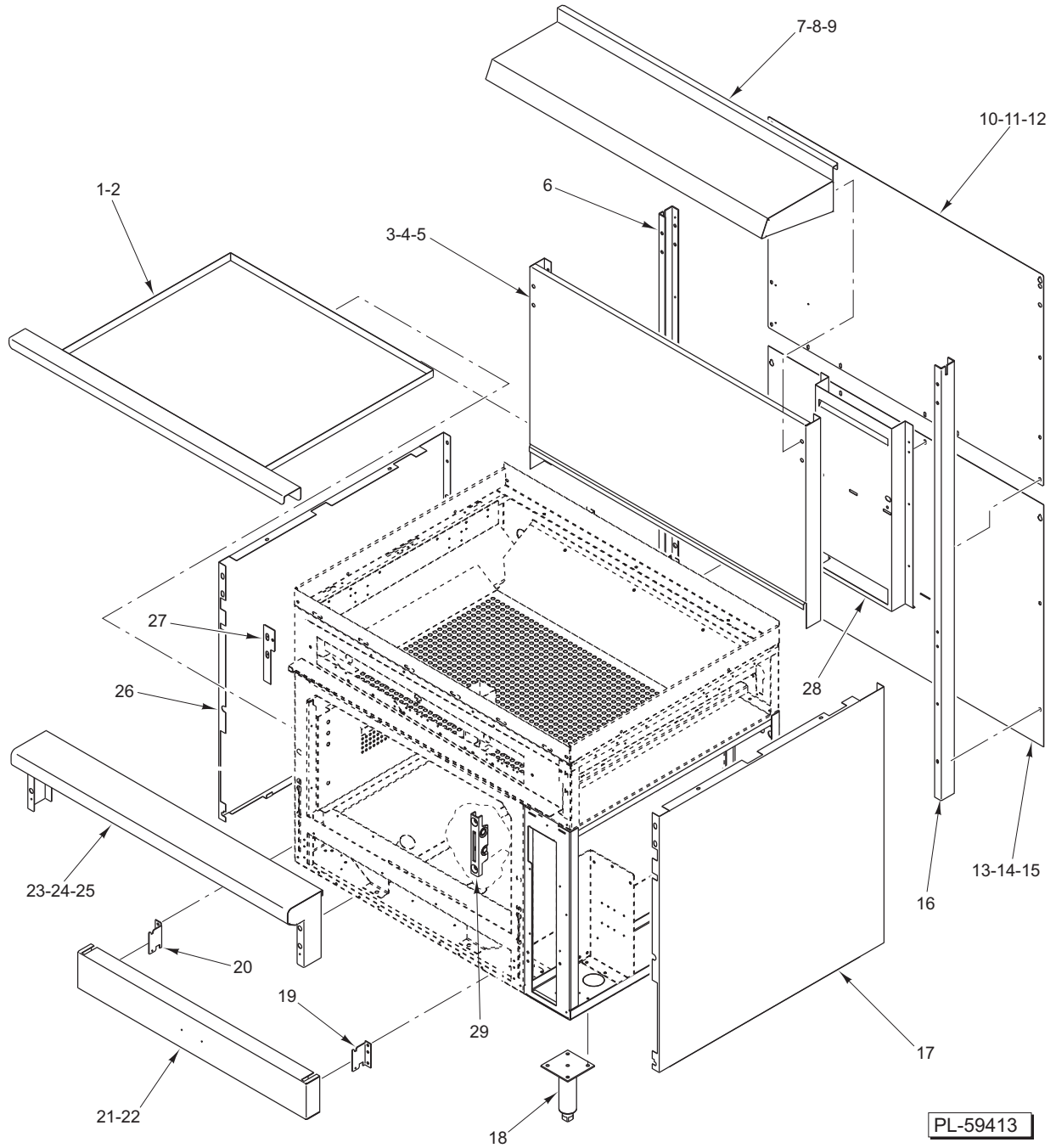

BODY (ML-137290, ML-137295, & ML-137303)

BODY (ML-137290, ML-137295, & ML-137303)

ILLUS. PL-59413	PART NO.	NAME OF PART	AMT.
1	00-921142-0000A	Tray – Crumb (24 In. Griddle) (ML-137290)	1
2	00-921044-0000A	Tray – Crumb (36 In. French Plate & Hot Top) (ML-137295 & ML-137303)	1
3	00-923507	Back Splash (24 In.) (ML-137290)	1
4	00-921053	Back Splash (36 In.) (ML-137303)	1
5	00-929006	Back Splash (60 In.) (ML-137295)	1
6	00-921051	Channel – Bayonet Back (LH)	1
7	00-923506-0000A	Shelf Assy. (24 In.) (ML-137290)	1
8	00-921038-0000A	Shelf Assy. (36 In.) (ML-137303)	1
9	00-929005-0000A	Shelf Assy. (60 In.) (ML-137295)	1
10	00-927404	Panel – Rear (ML-137290)	1
11	00-921054	Panel – Rear (ML-137303)	1
12	00-929007	Panel – Rear (ML-137295)	1
13	00-927418	Panel – Lower Rear Flue (24 In.) (ML-137290)	1
14	00-927468	Panel – Lower Rear Flue (36 In.) (ML-137303)	1
15	00-927416	Panel – Lower Rear Flue (60 In.) (ML-137295)	1
16	00-921052	Channel – Bayonet Back (RH)	AR
17	00-921047	Panel – Side (RH)	1
18	00-413112-00012	Leg (6 In.) (SST)	AR
19	00-921204	Bracket – Kick Panel Mounting (RH)	1
20	00-921203	Bracket – Kick Panel Mounting (LH)	1
21	00-921305-0000A	Kick Panel (24 In.) (ML-137290 & ML-137295)	1
22	00-921309-0000A	Kick Panel (36 In.) (ML-137303)	1
23	00-925490-0000A	Bullnose (24 In.) (ML-137290)	1
24	00-921017-0000A	Bullnose (36 In.) (ML-137303)	1
25	00-921005-0000A	Bullnose (60 In.) (ML-137295)	1
26	00-921048	Panel – Side (LH)	1
27	00-921058	Gasket – Bullnose	2
28	00-921083	Flue – Exhaust	1
29	00-497029-00001	Hinge – Door Stop	2
	00-927409	Guard – Thermostat Bulb	1

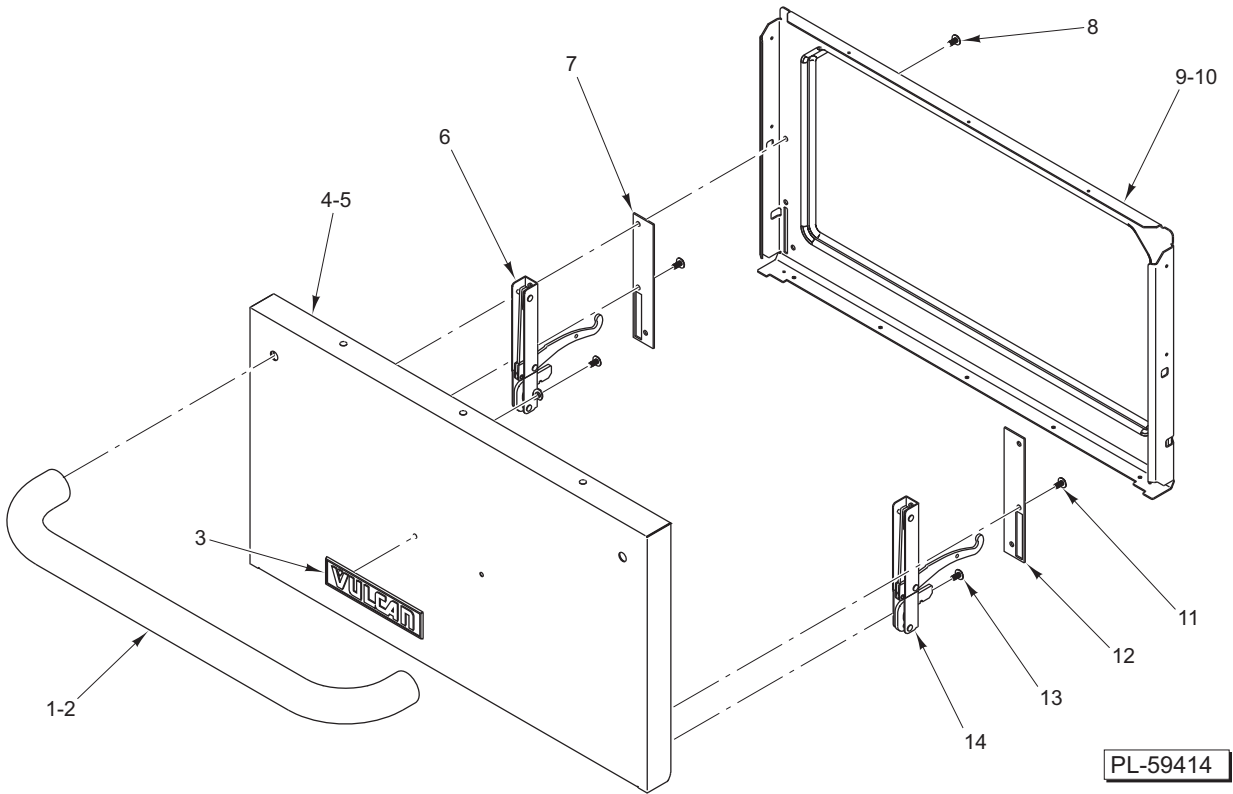

DOOR (ML-137290, ML-137295, & ML-137303)

DOOR (ML-137290, ML-137295, & ML-137303)

ILLUS. PL-59414	PART NO.	NAME OF PART	AMT.
1	00-941345	Handle –Oven (ML-137290 & ML-137295).....	AR
2	00-428618-00001	Handle – Oven (ML-137303)	1
3	00-928020	Nameplate – Vulcan (10 In.)	1
4	00-921302	Panel – Door (24 In.) (ML-137290 & ML-137295)	AR
5	00-921288	Panel – Door (30 In.) (ML-137303)	1
6	00-497027-00002	Hinge Assy. (LH)	1
7	00-921033	Insulation – Door Hinge	1
8	00-723369	Mach. Screw 1/4-20 x 1/2 Phil. Truss Hd.....	AR
9	00-922030	Liner – Door (24 In.) (ML-137290 & ML-137295)	AR
10	00-921090	Liner – Door (30 In.) (ML-137303)	1
11	00-723369	Mach. Screw 1/4-20 x 1/2 Phil. Truss Hd.....	AR
12	00-921033	Insulation – Door Hinge	1
13	00-723369	Mach. Screw 1/4-20 x 1/2 Phil. Truss Hd.....	AR
14	00-497027-00001	Hinge Assy. (RH).....	1
	00-923529	Insulation – Door (24 In.)	AR
	00-921102	Insulation – Door (30 In.)	AR
	00-921303-0000A	Door Assy. (ML-137290 & ML-137295).....	AR
	00-921287-0000A	Door Assy. (ML-137303)	1

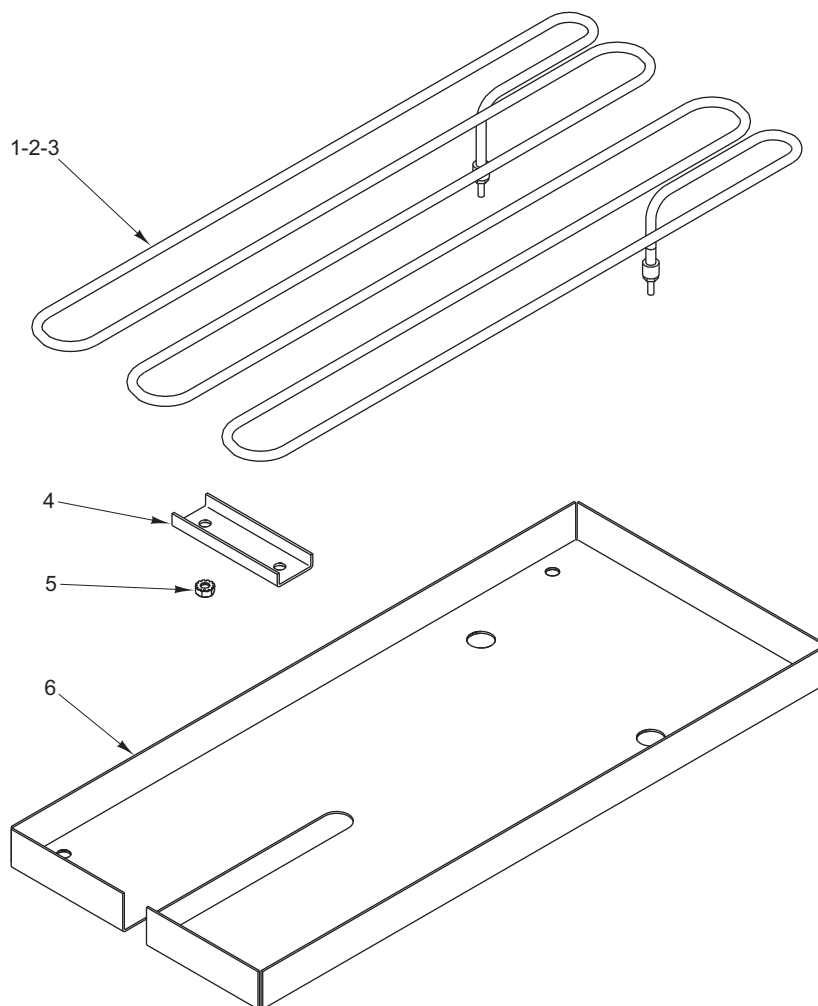

PL-59469

RANGE TOP ELEMENTS

RANGE TOP ELEMENTS

ILLUS.	PART NO.	NAME OF PART	AMT.
1	00-407774-00001	Element – Griddle (208 V.).....	AR
2	00-407774-00002	Element – Griddle (240 V.).....	AR
3	00-407774-00003	Element – Griddle (480 V.).....	AR
4	00-927415	Brace – Griddle Element.....	AR
5	NS-046-52	Nut Assy. 1/4-20 Hex.....	AR
6	00-421145	Cover – Griddle Element.....	AR
	00-927448-0000A	Griddle Assy. (12 In.) (208 V.).....	1
	00-927475-0000A	Griddle Assy. (12 In.) (240 V.).....	1
	00-927476-0000A	Griddle Assy. (12 In.) (480 V.).....	1
	00-927400-0000A	Griddle Assy. (24 In.) (208 V.).....	1
	00-927412-0000A	Griddle Assy. (24 In.) (240 V.).....	1
	00-927413-0000A	Griddle Assy. (24 In.) (480 V.).....	1
	00-927450-0000A	Griddle Assy. (36 In.) (208 V.).....	1
	00-927477-0000A	Griddle Assy. (36 In.) (240 V.).....	1
	00-927478-0000A	Griddle Assy. (36 In.) (480 V.).....	1
	00-497044-000G2	Harness – Griddle.....	1
	00-497376-000G2	Harness – Griddle (ML-137290 & ML-137304).....	1
	00-421320-00001	Top – Hot (208 V.) (ML-137290, ML-137303, & ML-137304).....	AR
	00-412320-00002	Top – Hot (240 V.).....	AR
	00-412320-00003	Top – Hot (480 V.).....	AR

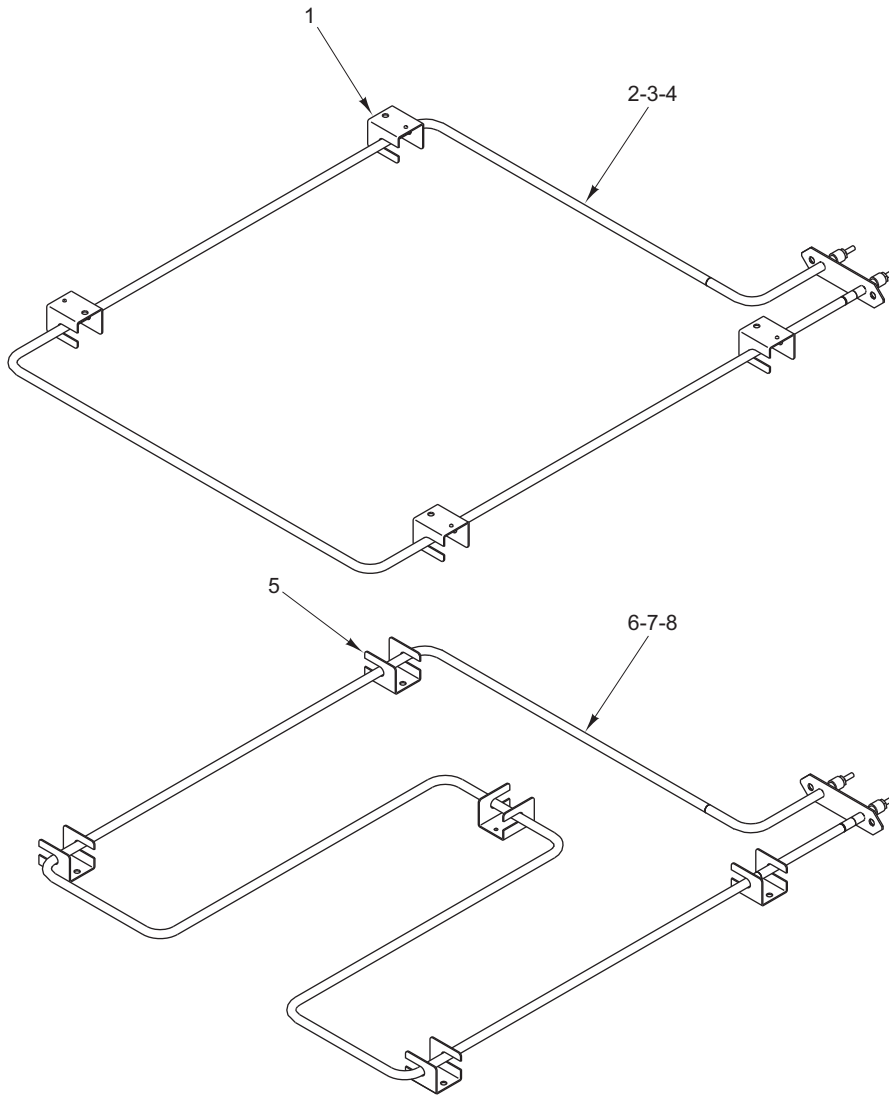

PL-59415

OVEN ELEMENTS (ML-137290, ML-137295, & ML137303)

ILLUS.	PART NO.	NAME OF PART	AMT.
PL-59415			
1	00-412925-00001	Clamp – Element	AR
2	00-927538-0004S	Oven Element Upper (208 V.).....	AR
3	00-927538-0005S	Oven Element Upper (240 V.).....	AR
4	00-927538-0006S	Oven Element Upper (480 V.).....	AR
5	00-412925-00001	Clamp – Element	AR
6	00-927538-0001S	Oven Element Lower (208 V.).....	AR
7	00-927538-0002S	Oven Element Lower (240 V.).....	AR
8	00-927538-0003S	Oven Element Lower (480 V.).....	AR

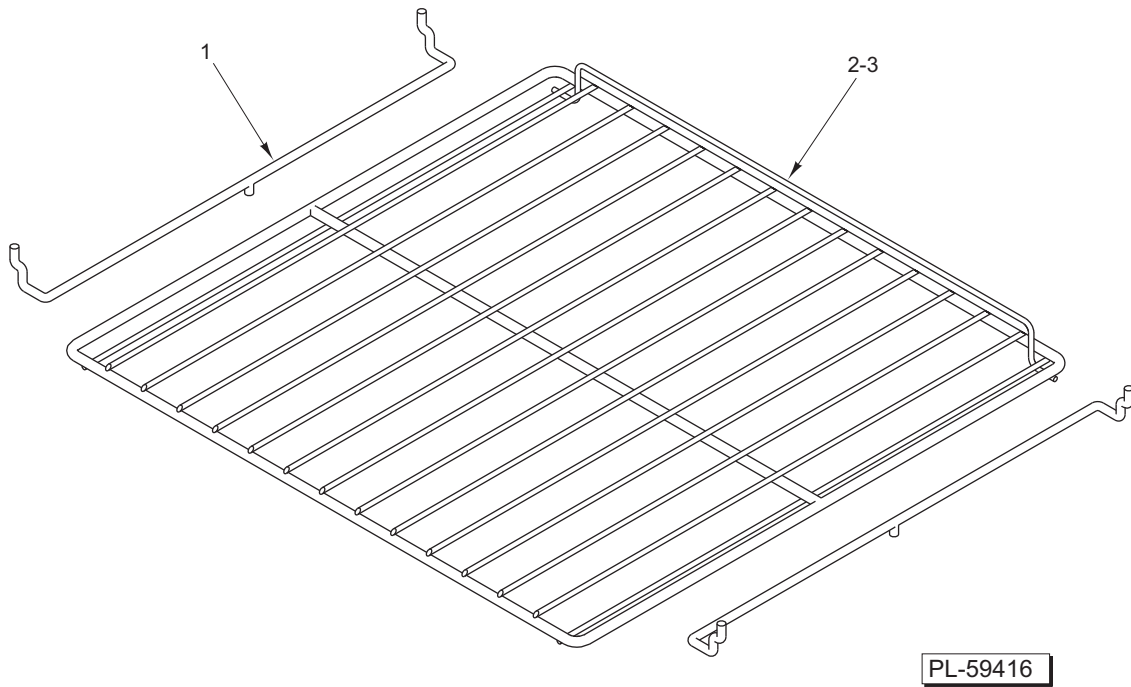

OVEN RACKS (ML-137290, ML-137295, & ML-137303)

ILLUS.	PART NO.	NAME OF PART	AMT.
PL-59416			
1	00-921064	Guide – Rack	AR
2	00-923508-0000A	Rack – Oven (24 In.) (ML-137290 & ML-137295)	AR
3	00-921010-0000A	Rack – Oven (ML-137303)	AR

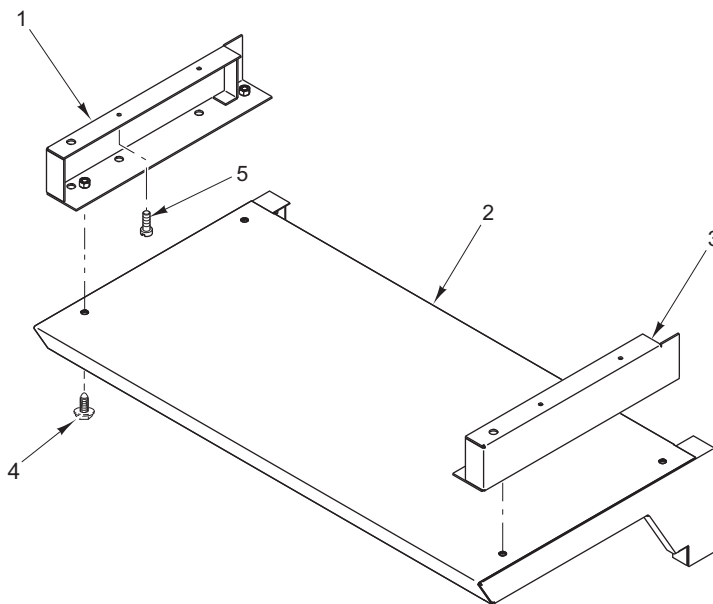

PL-59517

REINFORCED SHELF

REINFORCED SHELF

ILLUS. PL-59517	PART NO.	NAME OF PART	AMT.
1	00-921608-0000A	Bracket – Mounting Assy. (LH).....	1
2	00-921130-0000A	Shelf – Reinforced	1
3	00-921607-0000A	Bracket – Mounting Assy. (RH).....	1
4	00-730110	Bolt ³ / ₈ -16 x ³ / ₄ Hex Hd.....	4
5	00-730228	Self-Tapping Screw 10-24 x ¹ / ₂ Phil. Hex Hd.....	4

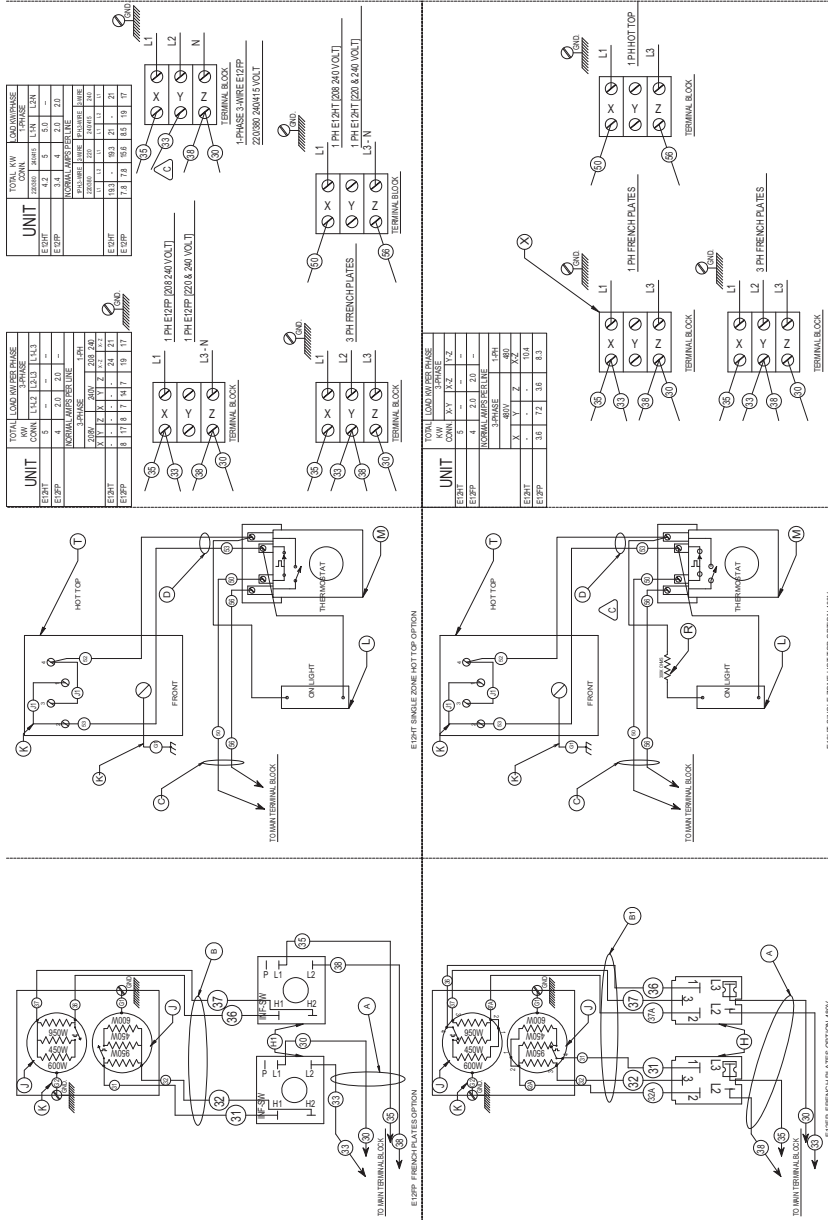

QTY	UNIT	DESCRIPTION	VOLTS	PART NO.
1	R	RESISTOR 300OHM	208 VOLT	44393-1
1	R	RESISTOR 300OHM	240 VOLT	44393-1
1	T	TEMPERATURE INDICATOR	240 VOLT	42702-2
1	T	TEMPERATURE INDICATOR	480 VOLT	42702-3
1	M	MELT FUSE	-	41193-1
1	L	LIGHT INDICATOR	-	42900-G1
2	K	WIRE ASSEMBLY (1)	-	419712-000AA
2	K	WIRE ASSEMBLY (2)	-	419712-000AA
2	J	FRENCH PLATE 600 2PH	208 VOLT	42700-1
2	J	FRENCH PLATE 600 2PH	240 VOLT	42700-2
2	H	SWITCH 3 HEAT	-	41193-4
2	H	SWITCH 3 HEAT	-	550796-1
1	D	HARNES, GROUPELEMENT	-	49704-G3
1	C	GRIDDLE SUPPLY HARNES	-	52700-02
1	B	FRENCH PLATE SUPPLY HARNES	-	52700-01
1	A	FRENCH PLATE SUPPLY HARNES	-	48704-G3

NOTE:
 EV12 208, 240 & 480 VOLT RANGES
 USE THE CORRECT VOLTAGE RANGES.
 SEE SUPPLY BLOCK WIRING FOR CONNECTION INFORMATION.

EV12 208, 240 & 480 VOLTS 220/380 240/415 VOLTS (927539 REV B)

WIRING DIAGRAMS

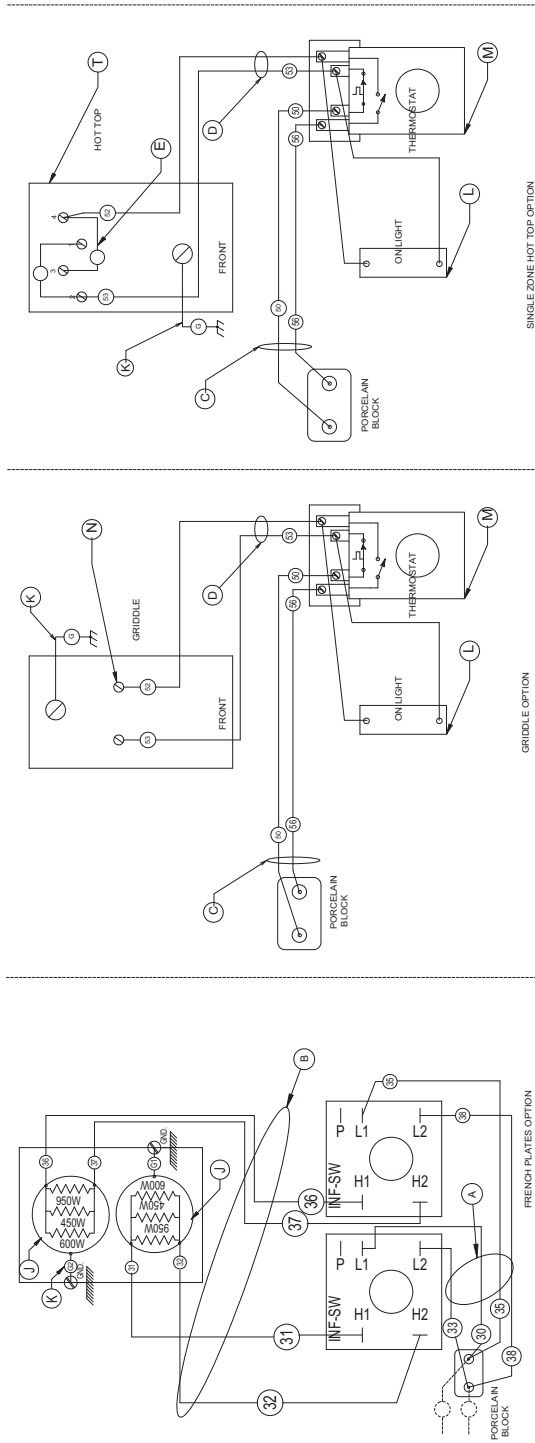

CONFIG	XY	YZ	ZX	1-PH	X	Y	Z	208V (AMPS)	240V (AMPS)	1-PH	X	Y	Z	1-PH
[]	5.0	3.4	3.4	11.8	35.0	28.3	56.7	30.3	30.3	24.5	49.2			
[]	5.0	3.4	4.0	12.4	37.5	30.8	59.6	32.5	30.3	26.7	51.7			
[]	5.0	4.0	4.0	13.0	37.5	33.3	62.5	32.5	32.5	28.9	54.2			
[]	5.0	5.0	4.0	14.0	37.5	41.6	67.3	32.5	36.1	32.5	58.3			
[]	5.0	3.4	5.0	13.4	41.6	35.0	64.4	36.1	30.3	30.3	55.8			
[]	5.0	4.0	5.0	14.0	41.6	37.5	67.3	36.1	32.5	32.5	58.3			
[]	5.0	5.0	5.0	15.0	41.6	41.6	72.1	36.1	36.1	36.1	62.5			

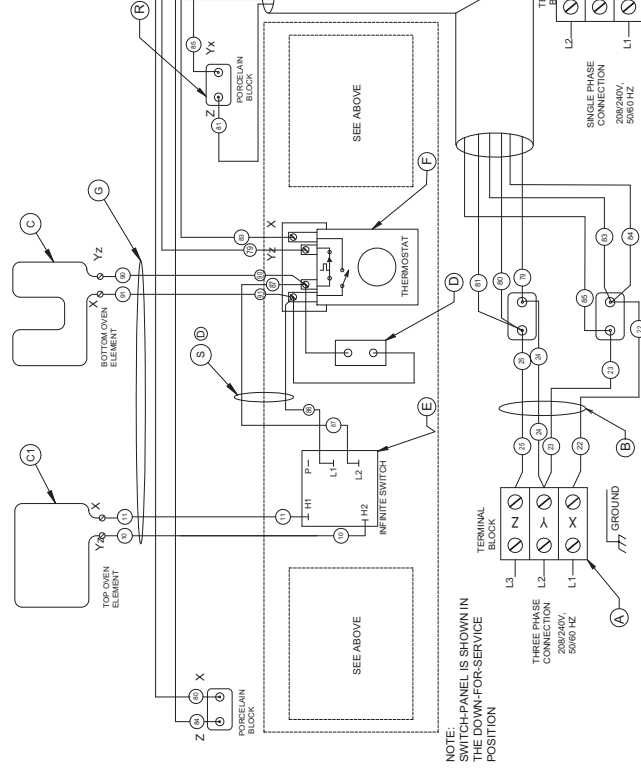

REQ. IT.	DESCRIPTION	PART NO.
1	S WIRES, TOP ELEM PWR	927599
4	R PORCELAIN BLOCK ASSEMBLY	41734-G1
1	N HARNESS MAIN [80 RIGHT]	927534-G1
1	H HARNESS MAIN [80 LT]	927533-G1
2	G HARNESS OVEN ELEMENT	927538-G1
2	F THERMOSTAT OVEN[S]	41856-14
2	E SWITCH INFINITE	41893-4
2	D LIGHT INDICATOR ASSEMBLY "OVEN"	42890-G3
2	C1 ELEMENT TOP 1.25KW	927538-4S
2	C ELEMENT BOTTOM 3.75KW	927538-5S
2	C ELEMENT BOTTOM 3.75KW	927538-1S
1	B HARNESS POWER [8]	927541-G1
-	A1 TERMINAL BLOCK 1 POLE/200/300	41087-9
2	A TERMINAL BLOCK 3 POLE	41087-8

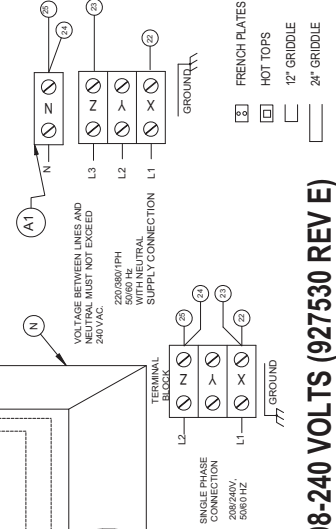

EV & EH 24" RANGES 208-240 VOLTS (927530 REV E)

WIRING DIAGRAMS

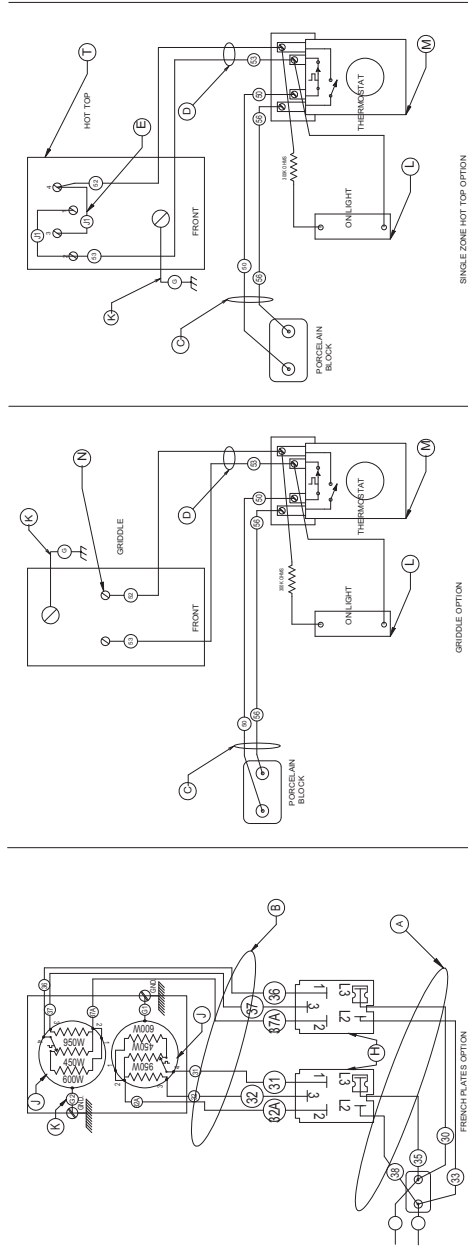

WIRING DIAGRAMS

- FRENCH PLATES
- HOT TOPS
- 12" GRIDDLE
- 24" GRIDDLE

CONFIG	KW			480V (AMPS)			
	XY	YZ	ZX	1-PH	X	Y	Z
	5.0	3.4	3.4	11.8	15.1	15.1	24.6
	5.0	3.4	4.0	12.4	16.3	15.1	25.8
	5.0	4.0	4.0	13.0	16.3	14.4	27.1
	5.0	5.0	4.0	14.0	16.3	16.3	29.1
	5.0	3.4	5.0	13.4	18.1	15.1	27.9
	5.0	4.0	5.0	14.0	18.1	16.3	29.1
	5.0	5.0	5.0	15.0	18.1	18.1	31.2

4	R	PORCELAIN BLOCK ASSEMBLY	-	4178-4-G1
1	N	HARNES MAN (R RIGHT)	-	9273-4-G1
1	H	HARNES MAN (R LT)	-	9273-5-G2
2	G	HARNES OVER ELEMENT	-	9273-5-G2
2	F	THERMO IN OVEN (SJ)	-	4170-1-14
2	E	SWITCH INFINITE	-	4170-1-14
2	D	LIGHT INDICATOR ASSEMBLY OVEN	-	4280-0-G3
2	C	ELEMENT TOP 1.25KW 480 VOLT	-	9273-5-6-5
2	C	ELEMENT BOTTOM 3.75KW 480 VOLT	-	9273-5-5-3
1	BH	HARNES POWER (R)	-	9274-1-G1
1	B	HARNES POWER (L)	-	9274-1-G1
1	A	TERMINAL BLOCK 3 POLE	-	-
1	A	TERMINAL BLOCK 3 POLE	-	4107-2-8
REQ	LT	DESCRIPTION		Part No.

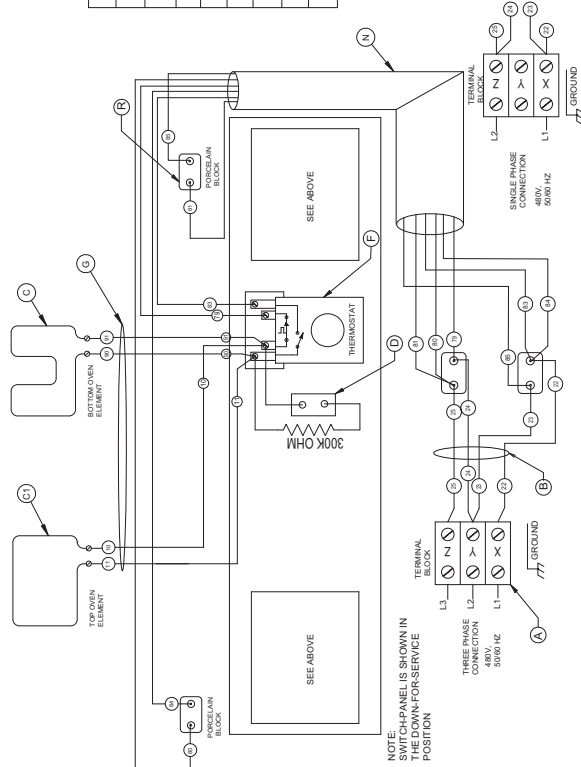

EV & EH 24" RANGES 480 VOLTS (927567 REV E)

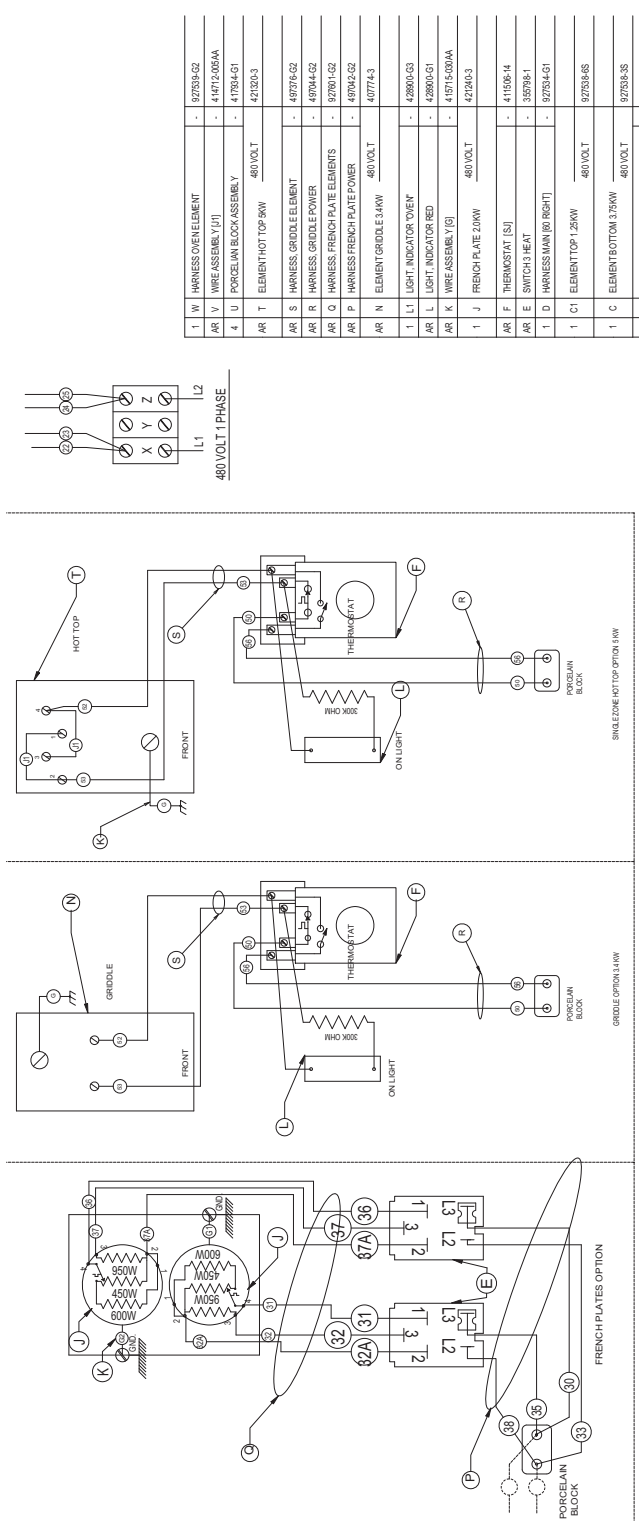

1	W	HARNES D'EN ELEMENT	-	927356-G2
AR	V	WIRE ASSEMBLY (H)	-	414712054A
4	U	PORCELAIN BLOCK ASSEMBLY	-	417383-G1
AR	T	ELEMENT HOT TOP 5KW	480 VOLT	421323-3
AR	S	HARNES GRIDDLE ELEMENT	-	4976-G2
AR	R	HARNES GRIDDLE POWER	-	49704-G2
AR	O	HARNES FRENCH PLATE ELEMENTS	-	92761-G2
AR	P	HARNES FRENCH PLATE POWER	-	49764-G2
AR	N	ELEMENT GRIDDLE 3.4KW	480 VOLT	40774-3
1	L1	LIGHT INDICATOR (VIEW)	-	42800-G3
AR	L	LIGHT INDICATOR (RED)	-	42800-G1
AR	K	WIRE ASSEMBLY (G)	-	419713084A
1	J	FRENCH PLATE 2.0KW	480 VOLT	421243-3
AR	F	THERMOSTAT (SU)	-	411595-14
AR	E	SWITCH (3 HEAT)	-	358795-1
1	D	HARNES MAIN (R) (RIGHT)	-	92734-G1
1	C1	ELEMENT TOP 1.25KW	480 VOLT	927358-G5
1	C	ELEMENT BOTTOM 3.75KW	480 VOLT	927352-G5
1	B	HARNES POWER 24	-	92754-G1
-	A1	TERMINAL BLOCK 1 POLE 220/280	-	41972-9
1	A	TERMINAL BLOCK 3 POLE	-	41972-8
FIG. / IT.		DESCRIPTION		(RM) / PART NO.

CONFIGURATION	KW			480 V (AMPS)					
	RIGHT SIDE	X-Y	Y-Z	Z-X	SINGLE PHASE	X	Y	Z	SINGLE PHASE
[]	5.0	3.4	3.4	11.8	15.1	15.1	12.2	24.6	
[]	5.0	3.4	4.0	12.4	16.3	15.1	13.3	25.8	
[]	5.0	4.0	4.0	13.0	16.3	16.3	14.4	27.1	
[]	5.0	5.0	4.0	14.0	16.3	18.1	16.3	28.1	
[]	5.0	3.4	5.0	13.4	18.1	15.1	15.1	27.9	
[]	5.0	4.0	5.0	14.0	18.1	16.3	16.3	28.1	
[]	5.0	5.0	5.0	15.0	18.1	18.1	18.1	31.2	

[] FRENCH PLATES [] HOT TOPS
 [] 12" GRIDDLE [] 24" GRIDDLE

WIRING DIAGRAMS

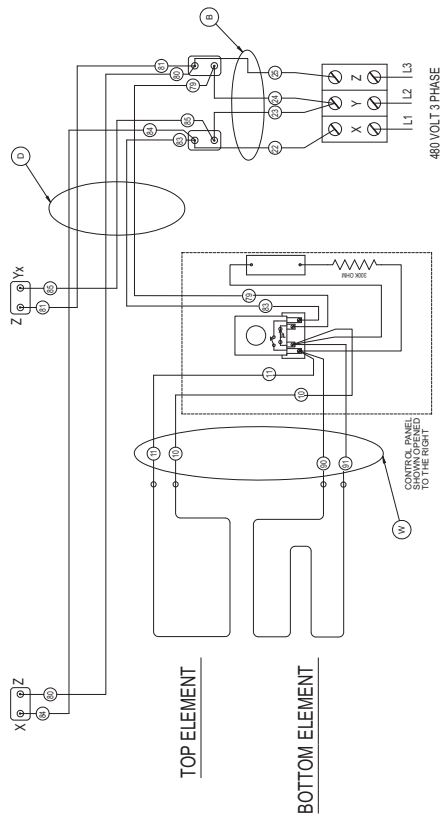

EV & EH 24" & 60" RANGES 480 VOLTS (927568 REV F)

EV SERIES RANGE REPLACEMENT PARTS

CONFIGURATION	208 V (AMPS)				240 V (AMPS)				
	RIGHT SIDE	XY	YZ	ZX	SINGLE PHASE	X	Y	Z	SINGLE PHASE
[Diagram]	5.0	3.4	3.4	3.4	11.8	35.0	28.3	35.0	56.7
[Diagram]	5.0	4.0	4.0	4.0	13.0	37.5	30.8	35.0	59.62
[Diagram]	5.0	4.0	4.0	4.0	13.0	37.5	33.3	37.5	62.5
[Diagram]	5.0	4.0	5.0	4.0	14.0	37.5	37.5	41.6	67.3
[Diagram]	5.0	5.0	3.4	4.0	13.4	35.0	35.0	64.4	36.1
[Diagram]	5.0	5.0	4.0	4.0	14.0	37.5	37.5	67.3	36.1
[Diagram]	5.0	5.0	5.0	5.0	15.0	41.6	41.6	41.6	72.1
[Diagram]	5.0	5.0	5.0	5.0	14.0	37.5	37.5	67.3	36.1
[Diagram]	5.0	5.0	5.0	5.0	14.0	37.5	37.5	67.3	36.1

1 X	WIRES TOP ELEMENT PWR	-	927599
1 W	HARNESS OVER ELEMENT	-	927596G1
AR V	WIRE ASSEMBLY(U)	-	41472000AA
4 U	POWELIAN BLOCK ASSEMBLY	-	417844G1
AR T	ELEMENT HOT TOP 9KW	208 VOLT	421300-1
AR S	HARNESS GRIDOLE ELEMENT	240 VOLT	421300-2
AR R	HARNESS GRIDOLE POWER	-	407944G2
AR Q	HARNESS FRENCH PLATE ELEMENTS	-	927944G1
AR P	HARNESS FRENCH PLATE POWER	-	407944G2
AR N	ELEMENT GRIDOLE 3.4KW	208 VOLT	407744-1
-	L1 LIGHT INDICATOR OVERVIEW	240 VOLT	407744-2
AR L	LIGHT INDICATOR RED	-	428900G1
AR K	WIRE ASSEMBLY(O)	-	415715A00AA
1 J	FRENCH PLATE 2.0KW	208 VOLT	427943
AR F	THERMOSTAT (S)	240 VOLT	427944
AR E	SWITCH INFINITE	-	414788-14
1 D	HARNESS MAIN	-	417834-1
2 C	ELEMENT MB 2.5KW	208 VOLT	927538-15
1 B	HARNESS POWER	240 VOLT	927538-15
-	A1 TERMINAL BLOCK POLE 202080	-	410012-9
1 A	TERMINAL BLOCK 3 POLE	-	410012-6
REG. ST.	REGISTRATION	PH	148714-6

- [Symbol] FRENCH PLATES
- [Symbol] 17" GRIDOLE
- [Symbol] HOT TOPS
- [Symbol] 24" GRIDOLE

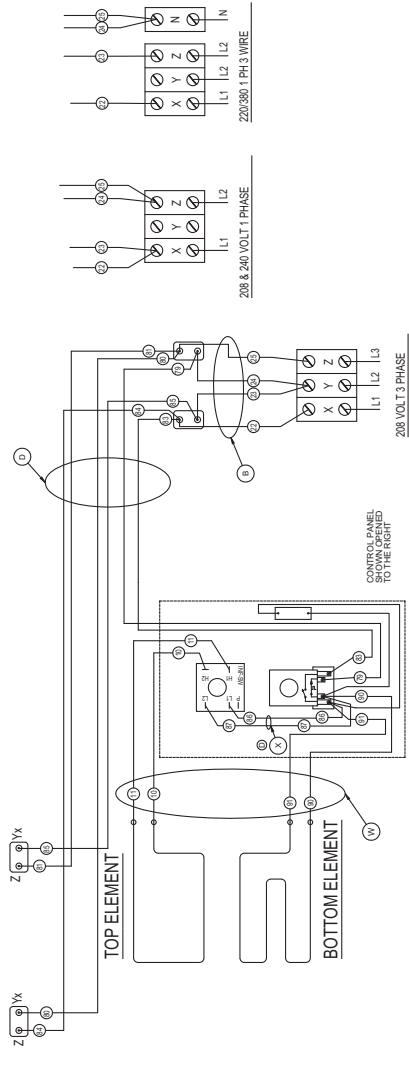
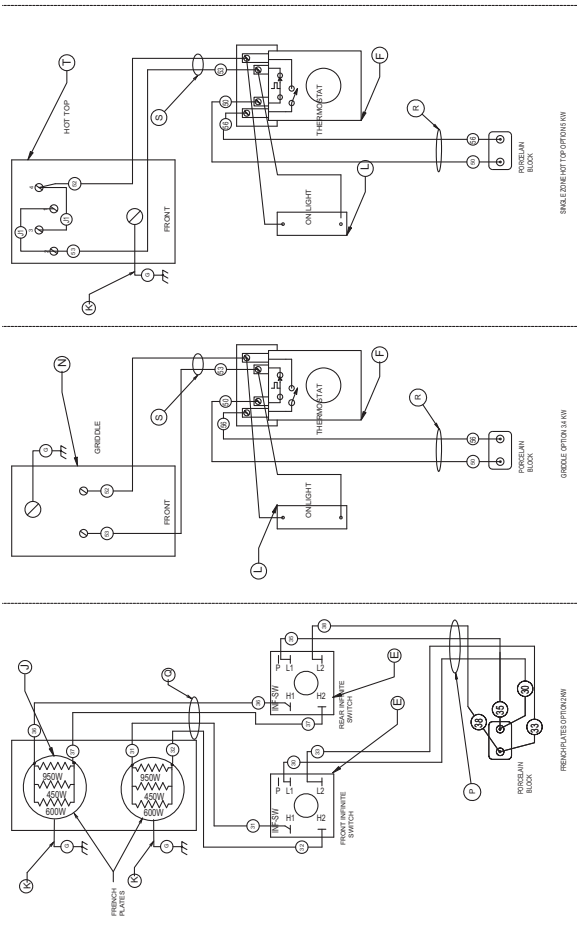

WIRING DIAGRAMS

EV & EH 24" & 60" RANGES (927566 REV F)

CONFIGURATION	KW			480AMPS				
	W	X	Y	Z	W	X	Y	Z
LEFT	3.4	6.8	5.0	15.2	15.15	16.4	21.3	31.7
RIGHT	3.4	7.4	5.0	16.8	15.15	19.5	22.35	32.9
FRONT	3.4	8.0	5.0	16.4	15.15	20.05	22.25	34.15
GRIDDLE	4.0	8.0	5.0	17.0	16.25	21.05	23.45	35.4
HOT TOP	5.0	8.0	5.0	18.0	16.05	23.65	23.45	37.5
FRONT	3.4	9.0	5.0	17.4	15.15	22.35	25.25	36.25
GRIDDLE	4.0	9.0	5.0	18.0	16.25	23.45	25.25	37.5
HOT TOP	5.0	9.0	5.0	19.0	16.05	25.25	25.25	39.6
FRONT	3.4	8.4	5.0	16.8	15.15	21.3	24.2	35.0
GRIDDLE	3.4	9.0	5.0	17.4	15.15	23.45	25.25	36.25
HOT TOP	4.0	9.0	5.0	18.0	16.25	23.45	25.25	37.5
FRONT	5.0	9.0	5.0	19.0	16.05	25.25	25.25	39.6
GRIDDLE	5.0	10.0	5.0	19.9	16.25	26.25	27.05	39.6
HOT TOP	5.0	10.0	5.0	20.0	16.05	27.05	27.05	41.65



1	W	HARNES OVERELEMENT	-	927535-G2
AR	V	WIRE ASSEMBLY (J)	-	414712-005AA
4	U	PORCELAIN BLOCK ASSEMBLY	-	417804-G1
AR	T	ELEMENT HOT TOP 5KW	480 VOLT	421262-3
AR	S	HARNES; GRIDDLE ELEMENT	-	497795-G2
AR	R	HARNES; GRIDDLE POWER	-	497044-G2
AR	Q	HARNES; FRENCH-PLATE ELEMENTS	-	927801-G2
AR	P	HARNES; FRENCH-PLATE POWER	-	497942-G2
AR	N	ELEMENT GRIDDLE 3.4KW	480 VOLT	407774-3
1	L1	LIGHT INDICATOR OVER*	-	428900-G3
AR	L	LIGHT INDICATOR RED	-	428900-G1
AR	K	WIRE ASSEMBLY (G)	-	415715-030AA
1	J	FRENCH PLATE Z 0KW	480 VOLT	421262-3
AR	F	THERMOSTAT (S)	-	411506-14
AR	E	SWITCH 3 HEAT	-	355798-1
1	D	HARNES MAIN	TOP 1.28KW	927538-G1
2	C	ELEMENT OVEN 480V	BOTTOM 3.75KW	927538-S3
1	B	HARNES POWER	-	927541-G1
-	A1	TERMINAL BLOCK 1 POLE 220/240	-	410427-9
1	A	TERMINAL BLOCK 3 POLE	-	410427-8
FIG. #		DESCRIPTION	PN	PKT NO.

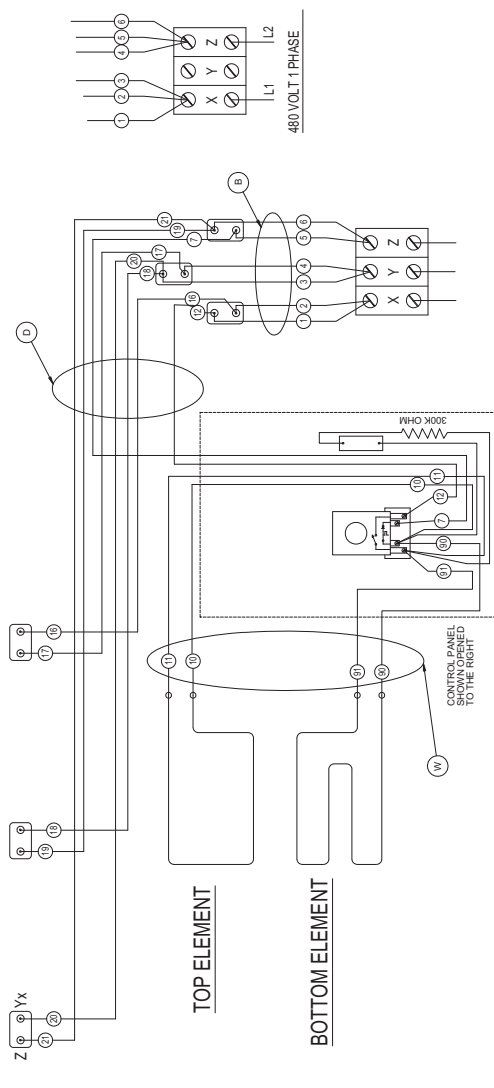
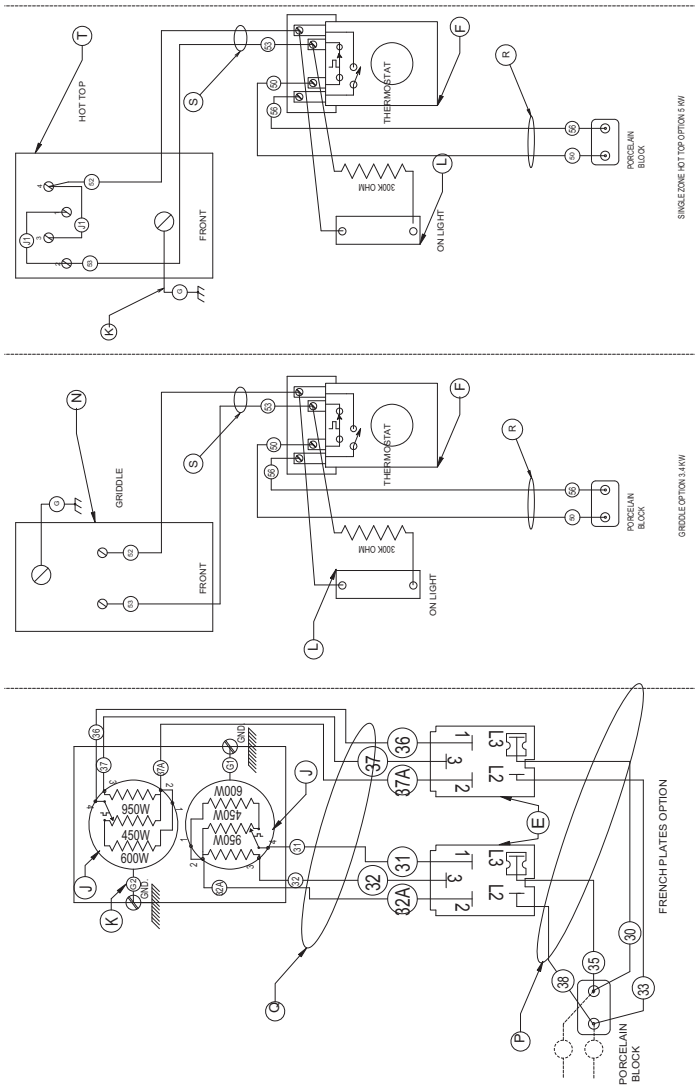

EV & EH 36" 480 VOLTS (927547 REV D)

WIRING DIAGRAMS

CONFIGURATION		120V			208V/240V			240V/208V					
LEFT	RIGHT	X-Y	Z-X	Y-Z	X	Y	Z	X	Y	Z			
FRONT	FRONT	3.4	6.8	5.0	15.2	35.0	42.5	48.1	73.1	30.3	36.5	42.5	63.3
FRONT	FRONT	3.4	7.4	5.0	15.8	35.0	46.0	51.6	76.0	30.3	38.0	44.7	66.8
FRONT	FRONT	3.4	8.0	5.0	16.4	35.0	47.5	54.1	78.8	30.3	34.1	40.9	60.3
FRONT	FRONT	4.0	8.0	5.0	17.0	37.5	50.0	54.1	81.7	32.5	43.3	48.9	70.8
FRONT	FRONT	3.4	9.0	5.0	18.0	41.6	54.1	54.1	86.5	36.1	46.9	49.9	75.0
FRONT	FRONT	3.4	9.0	5.0	17.4	39.0	51.6	58.3	83.7	30.3	44.7	50.5	72.5
FRONT	FRONT	4.0	9.0	5.0	19.0	41.6	54.1	58.3	86.5	36.1	46.9	50.5	75.0
FRONT	FRONT	5.0	9.0	5.0	19.0	41.6	58.3	58.3	91.4	36.1	50.5	50.5	79.2
FRONT	FRONT	3.4	8.4	5.0	18.8	39.0	46.1	55.8	80.8	30.3	42.6	48.4	70.0
FRONT	FRONT	4.0	9.0	5.0	18.0	37.5	51.6	58.3	83.7	30.3	44.7	50.5	72.5
FRONT	FRONT	5.0	9.0	5.0	19.0	41.6	58.3	58.3	91.4	36.1	50.5	50.5	79.2
FRONT	FRONT	3.4	10.0	5.0	19.4	39.0	58.3	62.5	88.5	30.3	48.4	51.1	76.7
FRONT	FRONT	4.0	10.0	5.0	19.0	37.5	58.3	62.5	91.4	32.5	50.5	51.1	79.2
FRONT	FRONT	5.0	10.0	5.0	20.0	41.6	62.5	62.5	96.2	36.1	54.1	54.1	83.3

T	X	WIRES, TOP ELEMENT	208 VOLT	52759-45
1	C2	ELEMENT TOP 1.75KW	240 VOLT	52759-45
T	W	HARNESSEVEN ELEMENT	240 VOLT	52759-45
AR	V	WIRESSEMBLY (U)		52759-45
U	U	POKELIN BLOCK ASSEMBLY		44712-088A
AR	T	ELEMENT HOT TOP #W	208 VOLT	41754-G1
AR	T	ELEMENT HOT TOP #W	240 VOLT	42130-1
AR	S	HARNESSEVEN ELEMENT	240 VOLT	42130-2
AR	R	HARNESSEVEN ELEMENT		48774-G2
AR	Q	HARNESSEVEN ELEMENT		48774-G2
AR	P	HARNESSEVEN ELEMENT		52761-G1
AR	N	HARNESSEVEN ELEMENT		48742-G2
AR	N	HARNESSEVEN ELEMENT		48774-1
AR	N	HARNESSEVEN ELEMENT		48774-2
AR	L	LIGHT INDICATOR "OVEN"		42800-G3
AR	L	LIGHT INDICATOR RED		42800-G1
AR	K	WIRESSEMBLY (S)		415715-030AA
1	J	FRENCH PLATE 2.0KW	208 VOLT	42124-3
AR	F	THERMOSTAT (SJ)		411006-14
AR	E	SWITCH INFINITE		41193-4
T	D	HARNESSEVEN ELEMENT	208 VOLT	52759-45
1	C1	ELEMENT BOT 3.75KW	240 VOLT	52759-45
1	B	HARNESSEVEN ELEMENT	240 VOLT	52759-45
-	A1	TERMINAL BLOCK 1 POLE 2/0380		41072-9
1	A	TERMINAL BLOCK 3 POLE		41072-9
REQ. IT.		DESCRIPTION	PH	PART NO.

- ⊗ FRENCH PLATES
- 12" GRIDDLE
- HOT TOPS
- 24" GRIDDLE
- 36" GRIDDLE

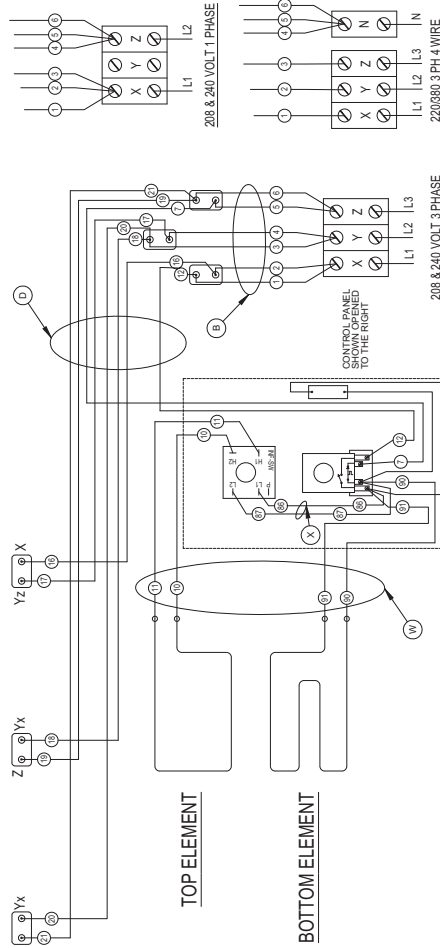
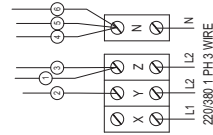
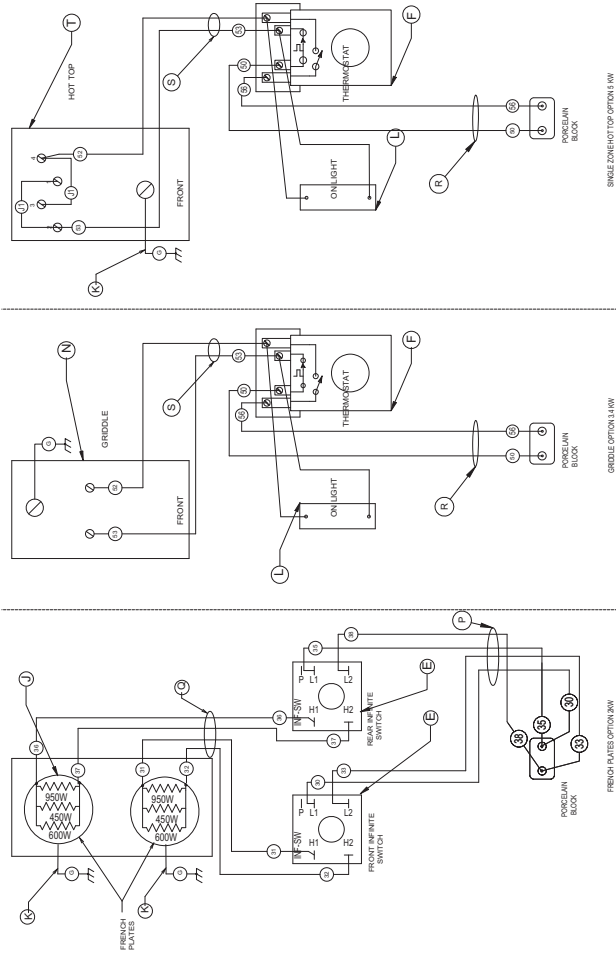

WIRING DIAGRAMS

EV & EH 36" & 60" RANGES 208-240 VOLTS (927505 REV E)

REPLACEMENT PARTS LIST

PART NO.	NAME OF PART
00-417876-00001	Resistor (300,000 Ohm)
00-414712-006AA	Wire Assy. – Hot Top
00-355798-00001	Switch – Range (4 Position)
00-421240-00001	Plate – French Ego (208 V.)
00-421240-00002	Plate – French Ego (240 V.)
00-421240-00003	Plate – French Ego 480 V.)
00-421320-00001	Top – Hot (208 V.)
00-421320-00002	Top – Hot (240 V.)
00-421320-00003	Top – Hot (480 V.)
00-415048-00001	Clamp – French Plates
00-927601-000G1	Harness – French Plate (208/240)
00-927539-000G2	Harness – Oven Element (480 V.)
00-927601-000G2	Harness – French Plate (480V.)
00-497042-000G2	Harness – French Plate Power
00-497044-000G2	Harness – Griddle
00-497376-000G2	Harness – Griddle Element
00-927533-000G1	Harness – Main (ML-137303 & ML-137295) (LH)
00-927539-000G1	Harness – Oven Element
00-927540-000G1	Harness – Power (ML-137290)
00-927541-000G1	Harness – Power ML-137303)
00-414715-030AA	Wire Assy. – Ground
00-411503-00004	Switch – Infinite (240 V.)
00-411506-00014	Thermostat (175-550 F.)
00-418061-00003	Dial – Thermostat 1-10
00-418060-00002	Dial – Thermostat
00-412251-00001	Infinite Switch – Knob
00-428900-000G1	Indicator – Light 2-Term
00-428900-000G3	Indicator – Light 2-Term Oven
00-499974-00001	Plug – Light
00-927538-0001S	Element (3.75 Kw, 208 Volt)
00-927538-0004S	Element (1.25 Kw, 208 Volt)
00-409642-00001	Label – Front
00-409642-00002	Plate – Rear
00-417856-00001	Lug – Ground
FE-023-53	Bushing – Electric Snap (1.5)
FE-023-56	Bushing – Heco (.875)
00-805782	Label – Disconnect Power
00-438131-00003	Label – Hot Surface
00-343979-00001	Label – Caution
00-410711-000D1	Decal – Ground
00-415049-00001	Strap – Jumper
00-927538-0002S	Element (3.75 Kw, 240 V.)
00-927538-0003S	Element (3.75 Kw, 480 V.)
00-927538-0005S	Element (1.25 Kw, 240 V.)
00-927538-0006S	Element (1.25 Kw, 480 V.)
00-410472-00009	Block – Terminal (1 Pole)
00-927534-000G1	Harness – Main (ML-137295) (RH)
00-407774-00001	Element – Griddle 208 V.
00-407774-00002	Element – Griddle 240 V.
00-407774-00003	Element – Griddle 480 V.
00-927599	Wire – Top Element Power