



CATALOG OF

REPLACEMENT PARTS



6614 MEAT SAW

ML-134096



6801 MEAT SAW

ML-134094

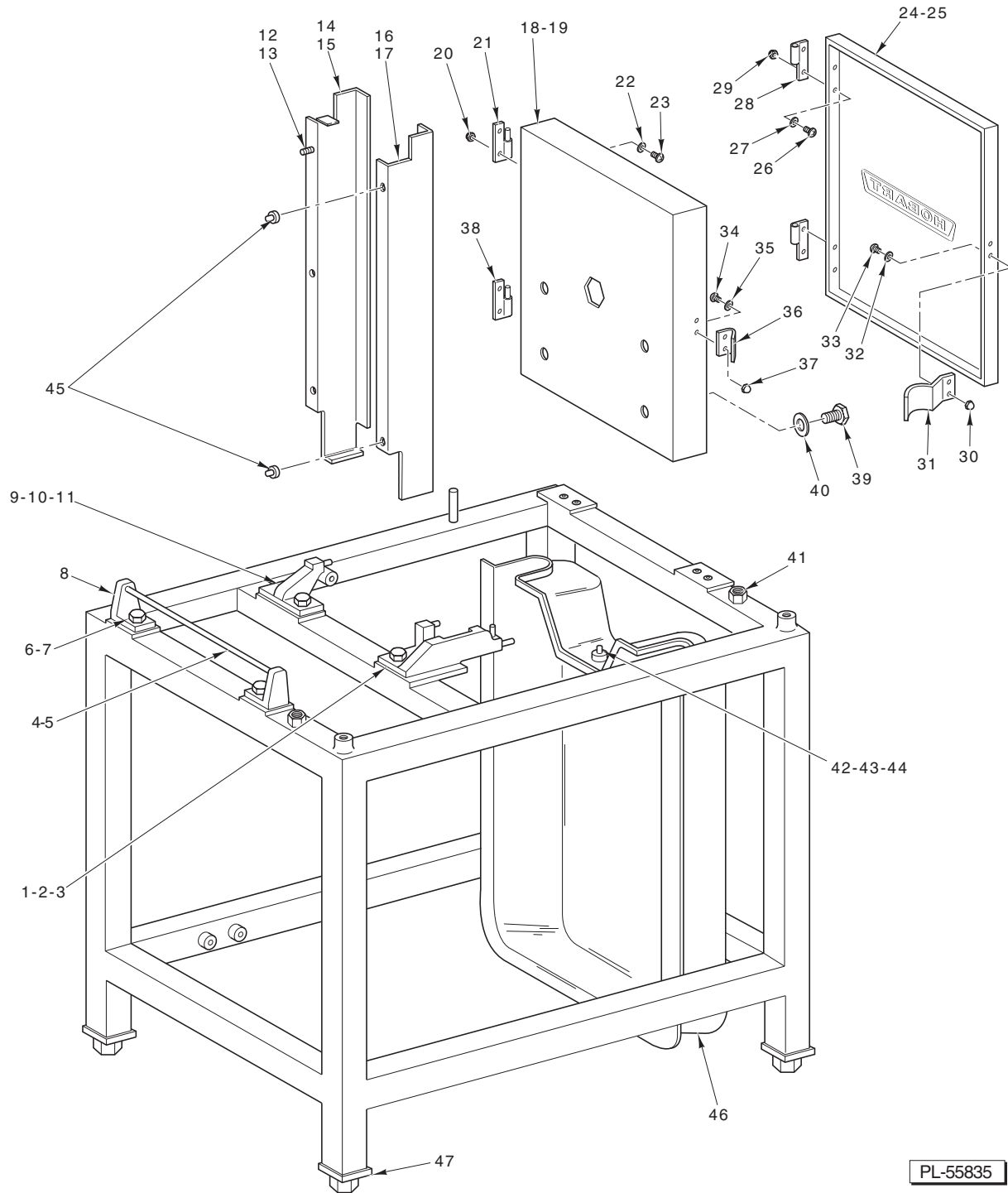

PL-55835

FRAME AND COVER

FRAME AND COVER

ILLUS.	PART NO.	NAME OF PART	AMT.
PL-55835			
1	00-291653	Lower Guide Support & Pin Assy.	1
2	SC-041-31	Cap Screw 3/8-16 x 1 1/4 Hex Hd.	2
3	WS-018-40	Washer	2
4	00-290758-00001	Rod – Anchor (Left Table) (Model 6801 ML-134094)	1
5	00-290758-00003	Rod – Anchor (Left Table) (Model 6614 ML-134096)	1
6	SC-041-31	Cap Screw 3/8-16 x 1 1/4 Hex Hd.	2
7	WS-018-40	Washer	2
8	00-290751	Support – Left Table	2
9	00-290752	Table Lock & Pin Assy.	1
10	SC-041-31	Cap Screw 3/8-16 x 1 1/4 Hex Hd.	2
11	WS-018-40	Washer	2
12	SC-093-07	Mach. Screw 10-32 x 1/2 Pan Hd.	3
13	WL-006-07	Lockwasher #10 Medium	3
14	00-875255	Guard – Column (Model 6801 ML-134094)	1
15	00-875087	Guard – Column (Model 6614 ML-134096)	1
16	00-875256	Guard – Removable (Model 6801 ML-134094)	1
17	00-875088	Guard – Removable (Model 6614 ML-134096)	1
18	00-873735	Upper Baffle Assy. (Incls. Items 20 thru 23 & 34 thru 38) (Model 6801 ML-134094)	1
19	00-875112	Upper Baffle Assy. (Incls. Items 20 thru 23 & 34 thru 38) (Model 6614 ML-134096)	1
20	NS-046-33	Acorn Nut 6-32 Hex	4
21	00-437676	Hinge – Bottom (W/Short Pin)	1
22	WS-028-03	Washer	4
23	SC-115-26	Mach. Screw 6-32 x 1/4 Slotted Pan Hd. (SST)	4
24	00-479153	Upper Cover Assy. (Incls. Items 26 thru 33) (Model 6801 ML-134094)	1
25	00-875111	Upper Cover Assy. (Incls. Items 26 thru 33) (Model 6614 ML-134096)	1
26	SC-115-26	Mach. Screw 6-32 x 1/4 Slotted Pan Hd. (SST)	4
27	WS-028-03	Washer	4
28	00-437378-00002	Hinge – Lift Off (W/O Pin)	2
29	NS-046-33	Acorn Nut 6-32 Hex	4
30	NS-046-33	Acorn Nut 6-32 Hex	2
31	00-291502	Clip – Latch	1
32	WS-028-03	Washer	2
33	SC-021-07	Mach. Screw 6-32 x 1/4 Rd. Hd. Slotted	2
34	SC-021-07	Mach. Screw 6-32 x 1/4 Rd. Hd. Slotted	2
35	WS-028-03	Washer	2
36	00-437608	Clip – Retainer	1
37	NS-046-33	Acorn Nut 6-32 Hex	2
38	00-437378-00003	Hinge – Lift Off (Bottom W/Pin)	1
39	SC-041-50	Cap Screw 1/4-20 x 1/2 Hex Hd.	4
40	WS-003-47	Washer	4
41	00-875054	Screw – Jack (Model 6614 ML-134096)	2
42	00-290860	Anchor – Lower Cover	1
43	SC-041-05	Cap Screw 1/4-20 x 5/8 Hex Hd.	1
44	WS-003-47	Washer	1
45	00-436908	Pin – Anchor	2
46	00-875036	Lower Cover W/Molded Handle (Incls. Items 42, 43, & 44)	1
47	00-435792	Foot (2" to 4" Adjustable Height)	4

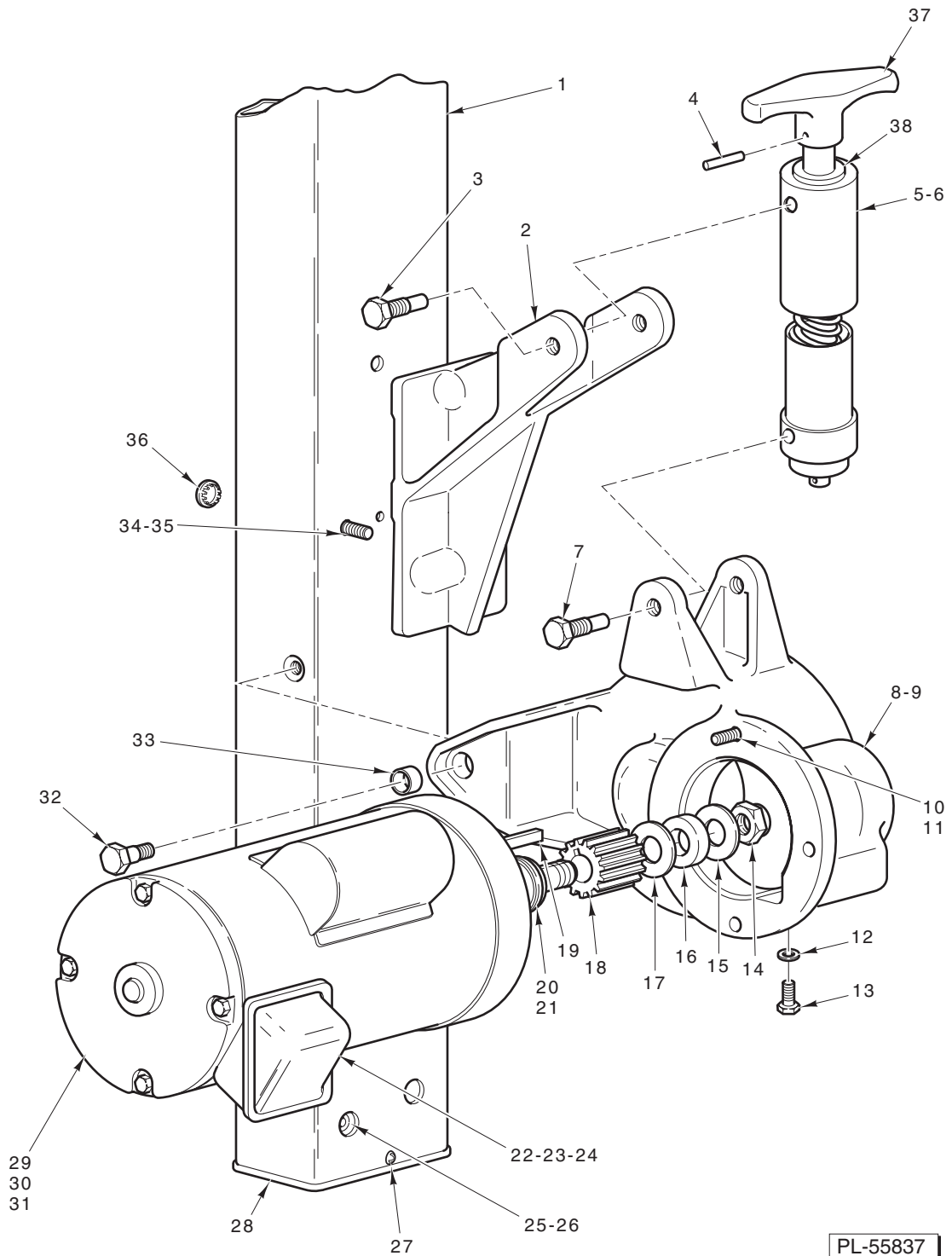

PL-55837

**DRIVE AND TENSION ADJUSTMENT UNIT
(MODEL 6614 ML-134096)**

**DRIVE AND TENSION ADJUSTMENT UNIT
(MODEL 6614 ML-134096)**

ILLUS. PL-55837	PART NO.	NAME OF PART	AMT.
1	00-875063	Column & Label Assy.	1
2	00-875047-00002	Transmission Support Assy.	1
3	00-290832	Pivot – Tension Adjusting	2
4	RP-003-16	Roll Pin ³ / ₁₆ x 1 Lg.	1
5	00-873500	Tensioner Assy. (Incls. Items 4, 6, 37, & 38)	1
6	BN-005-06	Needle Bearing – Torrington NTA-1018	1
7	00-290832	Pivot – Tension Adjusting	2
8	00-120971	Plug – Vent	1
9	00-875137	Gear Case Assy. (Incls. Items 8 & 33)	1
10	SC-041-31	Cap Screw ³ / ₈ -16 x 1 ¹ / ₄ Hex Hd.	3
11	WL-019-85	Lockwasher	3
12	WS-021-20	Washer	1
13	SC-036-93	Cap Screw ⁷ / ₁₆ -20 x ³ / ₄ Hex Hd.	1
14	NS-046-29	Lock Nut ³ / ₄ -16 Flexlox	1
15	SL-005-02	Spring – Loading	1
16	00-290866	Washer – Damper	1
17	SL-005-02	Spring – Loading	1
18	00-875043	Pinion – Drive	1
19	00-109070-00008	Key	1
20	SL-005-02	Spring – Loading	2
21	00-290866	Washer – Damper	1
22	SC-027-29	Mach. Screw 8-32 x ³ / ₈ Rd. Hd.	AR
23	WL-010-01	Lockwasher #8 External Shakeproof	AR
24	NS-010-11	Mach. Nut 8-32 Hex (Brass)	AR
25	SC-040-21	Cap Screw ³ / ₈ -16 x ⁷ / ₈ Soc. Hd.	4
26	WL-004-06	Lockwasher ³ / ₈ Medium	4
27	SD-038-03	Self-Tapping Screw 10-16 x ³ / ₄ Truss Hd.	2
28	00-479134	End Cap	1
29	00-437301-00001	Motor (60 Hz.) (3 Ph.)	1
30	00-437301-00003	Motor (50 Hz.) (3 Ph.)	1
31	00-479005	Motor (1 Ph.)	1
32	00-873986	Screw Shoulder	2
33	00-291859-00002	Bushing ³ / ₈ Lg.	2
34	SC-040-21	Cap Screw ³ / ₈ -16 x ⁷ / ₈ Soc. Hd.	5
35	WS-018-04	Washer	5
36	PB-004-92	Plug Button	13
37	00-873456	Handle	1
38	BB-021-45	Bearing – Thrust 0.6371	1
	00-875114-00001	Motor & Pinion Assy. (60 Hz.) (3 Ph.) (Incls. Items 14 thru 21 & 29)	1
	00-875114-00003	Motor & Pinion Assy. (60 Hz.) (1 Ph.) (Incls. Items 14 thru 21 & 31)	1

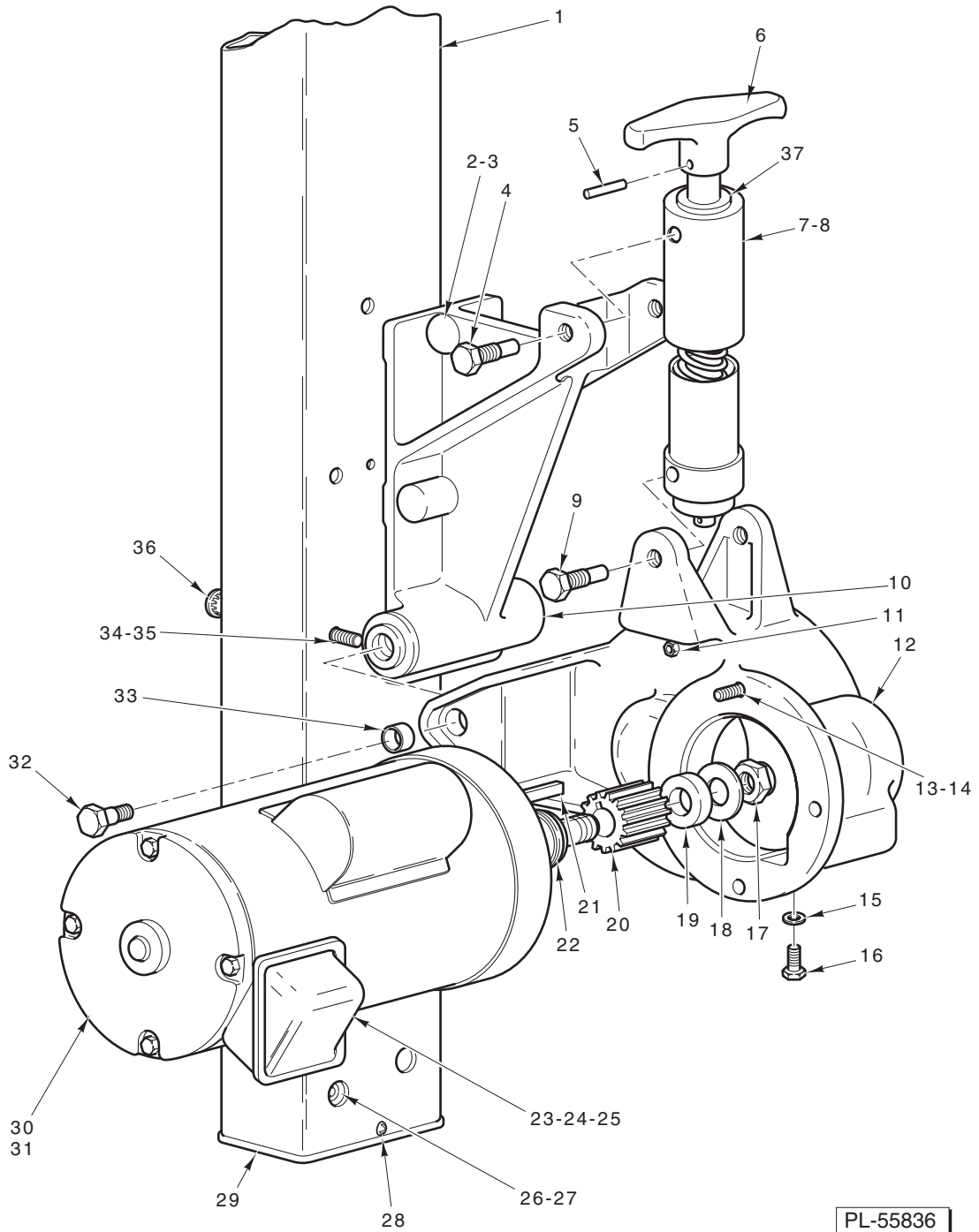

**DRIVE AND TENSION ADJUSTMENT UNIT
(MODEL 6801 ML-134094)**

**DRIVE AND TENSION ADJUSTMENT UNIT
(MODEL 6801 ML-134094)**

ILLUS.	PART NO.	NAME OF PART	AMT.
	PL-55836		
1	00-873696-00001	Column & Label Assy.	1
2	00-292286-00002	Transmission Support Assy. (Incls. Item 3)	1
3	00-011800-00118	Dowel	1
4	00-290832	Pivot – Tension Adjusting	2
5	RP-003-16	Roll Pin ³ / ₁₆ x 1 Lg.	1
6	00-873456	Handle	1
7	00-873500	Tensioner Assy. (Incls. Items 5, 6, 8, & 37)	1
8	BN-005-06	Needle Bearing – Torrington NTA-1018	1
9	00-290832	Pivot – Tension Adjusting	2
10	00-291859-00001	Bushing ¹ / ₂ Lg.	1
11	00-120971	Plug – Vent	1
*12	00-875137	Gear Case Assy. (Incls. Item 11)	1
13	SC-041-31	Cap Screw ³ / ₈ -16 x 1 ¹ / ₄ Hex Hd.	3
14	WL-019-85	Lockwasher	3
15	WS-021-20	Washer	1
16	SC-036-93	Cap Screw ⁷ / ₁₆ -20 x ³ / ₄ Hex Hd.	1
17	NS-046-29	Lock Nut ³ / ₄ -16 Flexlox	1
18	SL-005-02	Spring – Loading	1
19	00-290866	Washer – Damper	1
20	00-875043	Pinion – Drive (14T)	1
21	00-109070-00008	Key	1
22	SL-005-02	Spring – Loading	6
23	SC-027-29	Mach. Screw 8-32 x ³ / ₈ Rd. Hd.	AR
24	WL-010-01	Lockwasher #8 External Shakeproof	AR
25	NS-010-11	Mach. Nut 8-32 Hex (Brass)	AR
26	SC-040-21	Cap Screw ³ / ₈ -16 x ⁷ / ₈ Soc. Hd.	4
27	WL-004-06	Lockwasher ³ / ₈ Medium	4
28	SD-038-03	Self-Tapping Screw 10-16 x ³ / ₄ Truss Hd.	2
29	00-479134	End Cap	1
30	00-437301-00001	Motor (60 Hz.) (3 Ph.)	1
31	00-479005	Motor (1 Ph.)	1
32	00-873986	Screw Shoulder	1
33	00-291859-00001	Bushing ¹ / ₂ Lg.	2
34	SC-040-21	Cap Screw ³ / ₈ -16 x ⁷ / ₈ Soc. Hd.	5
35	WS-018-04	Washer	5
36	PB-004-92	Plug Button	8
37	BB-021-45	Bearing – Thrust 0.6371	1

*Gear case supplied with (2) 00-291859-00002 Bushings, replace with (2) 00-291859-00001 Bushings when servicing this ML.

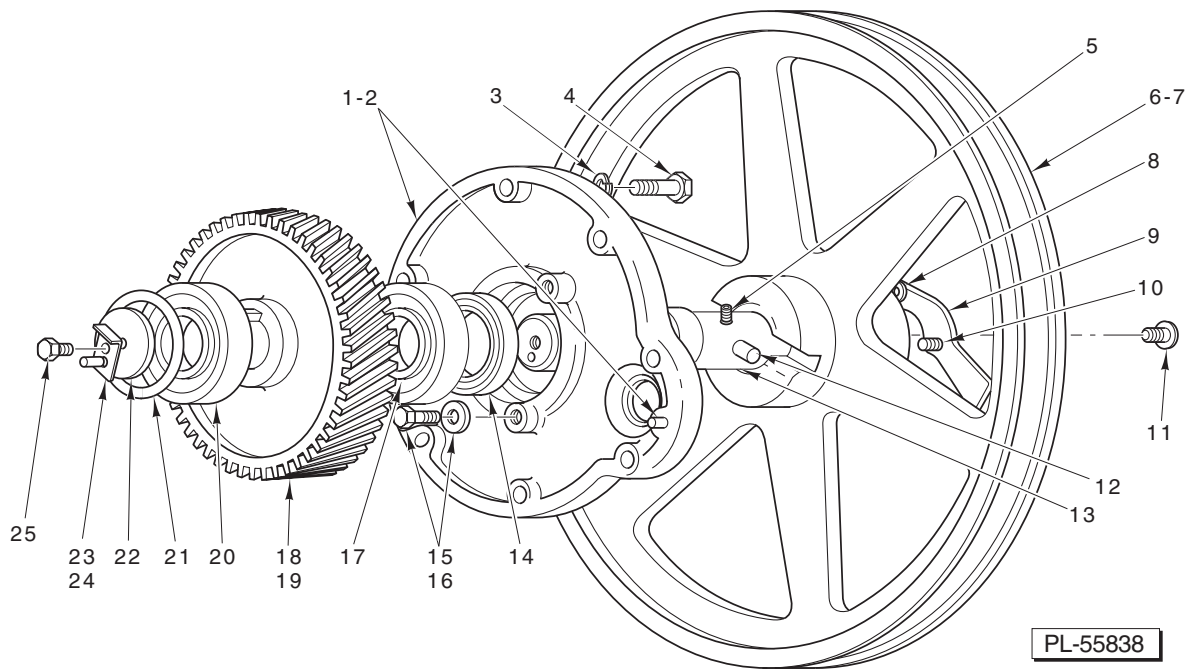

LOWER PULLEY UNIT

LOWER PULLEY UNIT

ILLUS. PL-55838	PART NO.	NAME OF PART	AMT.
1	00-290817-00002	Gear Case Cover Assy. (Incls. Item 2)	1
2	00-011800-00091	Dowel	2
3	WL-006-22	Lockwasher ⁵ / ₁₆ Light	7
4	SC-041-15	Cap Screw ⁵ / ₁₆ -18 x 1 ¹ / ₄ Hex Hd.	7
5	SC-119-20	Set Screw ¹ / ₄ -20 x ¹ / ₂ Soc. Hdls., Flat Pt.	1
6	00-108228-00004	Pulley (Model 6614 ML-134096)	1
7	00-435582	Pulley (Model 6801 ML-134094)	1
8	00-079686	Catch – Friction	1
9	00-875150	Latch	1
10	00-020851	Screw – Latch	1
11	SD-005-49	Self-Tapping Screw 12 x ¹ / ₂ Rd. Hd., Type U	1
12	00-436447	Drive Pin	1
13	00-292278	Shaft – Lower	1
14	00-290805	Seal – Shaft	1
15	SC-036-24	Cap Screw ⁵ / ₁₆ -18 x ⁵ / ₈ Hex Hd.	3
16	WS-018-19	Washer	3
17	BB-008-14	Ball Bearing	1
18	00-875044-00002	Gear – Drive (58T)	1
19	00-109070-00009	Key	1
20	BB-021-53	Ball Bearing	1
21	SL-003-11	Spring – Loading ND 72	2
22	00-291973-00002	Retainer – Shaft	1
23	00-291624	Retainer – Lock	1
24	RP-003-18	Roll Pin ¹ / ₈ x ⁷ / ₈ Lg.	1
25	SC-041-13	Cap Screw ⁵ / ₁₆ -18 x 2	1
	00-479466	Drive Unit – Lower (Incls. Items 13, 17 thru 20, & 22 thru 25)	1
	ML-109658-0000Z	Pulley and Latch Assy. (Incls. Items 6, 8, 9, & 10) (Model 6614 ML-134096)	1
	ML-109653-0000Z	Pulley and Latch Assy. (Incls. Items 7 thru 10) (Model 6801 ML-134094)	1

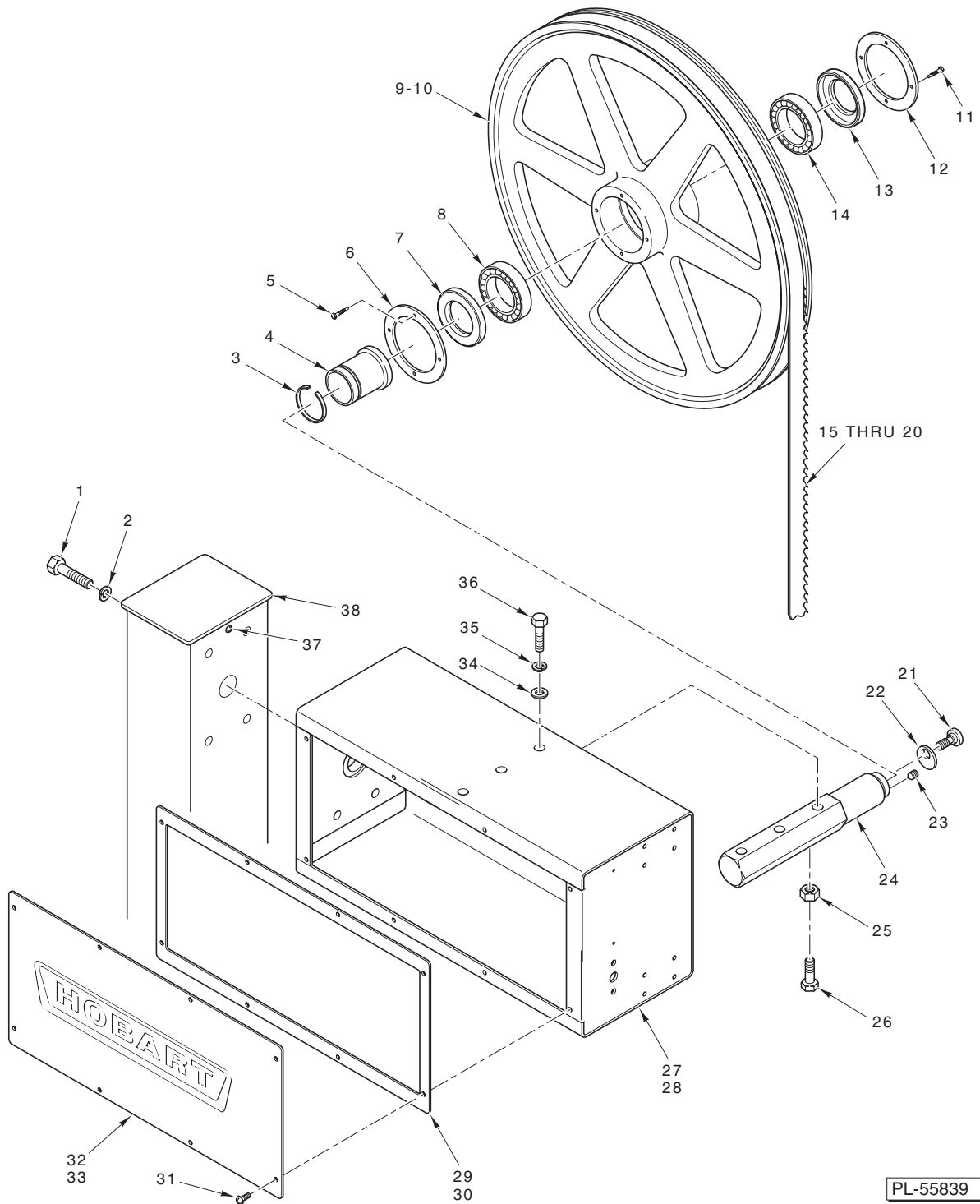

UPPER BEARING CARRIER UNIT

UPPER BEARING CARRIER UNIT

ILLUS. PL-55839	PART NO.	NAME OF PART	AMT.
1	SC-040-21	Cap Screw $\frac{3}{8}$ -16 x $\frac{7}{8}$ Soc. Hd.	4
2	WL-004-06	Lockwasher $\frac{3}{8}$ Medium	4
3	RR-004-13	Retaining Ring (Truarc)	1
4	00-479143	Bushing – Pulley	1
5	SC-067-06	Mach. Screw 10-24 x $\frac{1}{2}$ Hex Hd.	4
6	00-873461-00002	Cover – Rear Pulley	1
7	00-873501	Seal – Shaft	1
8	BB-015-36	Ball Bearing – NSK 6007 DDUCE1SRIS	1
9	ML-134048-0000Z	Pulley Assy. – Upper (Packaged) (Model 6614 ML-134096)	1
10	ML-104999-0000Z	Pulley Assy. – Upper (Packaged) (Model 6801 ML-134094)	1
11	SC-067-06	Mach. Screw 10-24 x $\frac{1}{2}$ Hex Hd.	4
12	00-873461-00001	Cover – Front Pulley	1
13	00-873502	Seal – Shaft	1
14	BB-015-36	Ball Bearing – NSK 6007 DDUCE1SRIS	1
15	00-477011-00126	Blade – Saw ($\frac{5}{8}$ In. Wd. x 0.022 Thk.) (3T) (Model 6614 ML-134096)	1
16	00-477016-00126	Blade – Saw ($\frac{5}{8}$ In. Wd. x 0.022 Thk.) (4T) (Model 6614 ML-134096)	1
17	00-477086-00126	Blade – Saw ($\frac{5}{8}$ In. Wd. x 0.025 Thk.) (Scalloped) (Model 6614 ML-134096)	1
18	00-477011-00142	Blade – Saw ($\frac{5}{8}$ In. Wd. x 0.022 Thk.) (3T) (Model 6801 ML-134094)	1
19	00-477016-00142	Blade – Saw ($\frac{5}{8}$ In. Wd. x 0.022 Thk.) (4T) (Model 6801 ML-134094)	1
20	00-477086-00142	Blade – Saw ($\frac{5}{8}$ In. Wd. x 0.025 Thk.) (Scalloped) (Model 6801 ML-134094)	1
21	00-020851	Screw – Latch	1
22	00-479142	Retainer – Pulley	1
23	00-079686	Catch – Friction	1
24	00-479144	Shaft – Upper	1
25	NS-018-14	Jam Nut $\frac{3}{8}$ -16 Hex	2
26	SC-127-03	Cap Screw – $\frac{3}{8}$ -16 x $1\frac{3}{4}$ Hex Hd.	2
27	00-875072	Box Column Assy. (Model 6614 ML-134096)	1
28	00-875227	Box Column Assy. (60 Hz.) (Model 6801 ML-134094)	1
29	00-875080	Gasket – Column Box (Model 6614 ML-134096)	1
30	00-873820	Gasket – Column Box (Model 6801 ML-134094)	1
31	SC-025-33	Mach. Screw 8-32 x $\frac{1}{2}$ Bndg. Hd.	8
32	00-875077	Cover – Column Box (Model 6614 ML-134096)	1
33	00-479672	Cover – Column Box (60 Hz.) (Model 6801 ML-134094)	1
34	WS-018-40	Washer (Model 6614 ML-134096)	3
35	WL-006-27	Lockwasher $\frac{3}{8}$ Light	3
36	SC-041-31	Cap Screw $\frac{3}{8}$ -16 x $1\frac{1}{4}$ Hex Hd.	3
37	00-479134	End Cap	1
38	SD-038-03	Self-Tapping Screw 10-16 x $\frac{3}{4}$ Truss Hd.	2

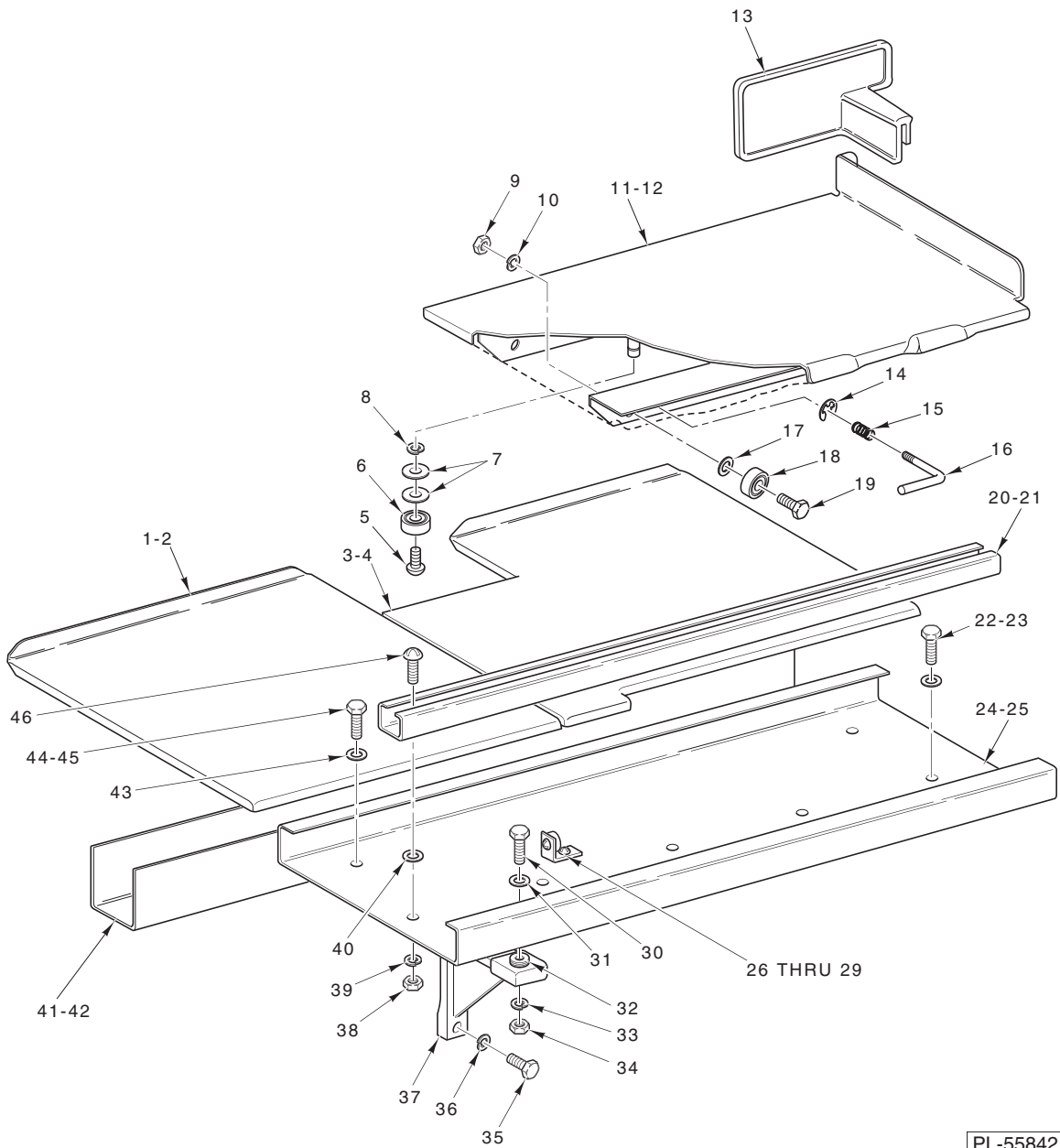

PL-55842

UPPER BEARING CARRIER UNIT

TABLES AND CARRIAGE UNIT

ILLUS.	PART NO.	NAME OF PART	AMT.
	PL-55842		
1	00-290771	Table – Left Assy. (Model 6801 ML-134094)	1
2	00-875066	Table – Left Assy. (Model 6614 ML-134096)	1
3	00-291654	Table – Right Assy. (Model 6801 ML-134094)	1
4	00-875068	Table – Right Assy. (Model 6614 ML-134096)	1
5	SC-041-30	Cap Screw $\frac{3}{8}$ -16 x 1 Hex Hd. (SST)	2
6	BB-008-11	Ball Bearing – Nice #SK-T 4725	2
7	WS-018-30	Washer	4
8	WL-006-28	Lockwasher $\frac{3}{8}$ Medium	2
9	NS-046-09	Stop Nut $\frac{3}{8}$ -16 Elastic	4
10	WL-006-27	Lockwasher $\frac{3}{8}$ Light	4
11	00-437469	Carriage Assy. (Model 6801 ML-134094)	1
12	00-875136	Carriage Assy. (Model 6614 ML-134096)	1
13	00-291435	Pusher Plate	1
14	RR-011-09	Retaining Ring	1
15	00-290787	Spring – Carriage Lock	1
16	00-290795	Lever – Carriage Lock	1
17	WS-018-34	Washer (Model 6801 ML-134094)	4
18	BB-008-11	Ball Bearing – Nice #SK-T 4725	4
19	SC-041-30	Cap Screw $\frac{3}{8}$ -16 x 1 Hex Hd.	4
20	00-437476	Guide – Roller (Model 6801 ML-134094)	1
21	00-875089	Guide – Roller (Model 6614 ML-134096)	1
22	SC-041-29	Cap Screw $\frac{3}{8}$ -16 x $\frac{7}{8}$ Hex Hd. Wax Coated Threads (Model 6614 ML-134096)	2
23	WS-018-40	Washer (Model 6614 ML-134096)	2
24	00-873790	Support – Carriage (Model 6801 ML-134094)	1
25	00-875091	Support – Carriage (Model 6614 ML-134096)	1
26	00-479107	Stop – Carriage	1
27	SC-124-44	Bolt – Sq. Neck $\frac{5}{16}$ -18 x $\frac{3}{4}$ Rd. Hd.	2
28	NS-036-19	Stop Nut $\frac{5}{16}$ -18 Elastic	2
29	00-873789	Bumper – Carriage Stop	1
30	SC-041-34	Cap Screw $\frac{3}{8}$ -16 x 2 Hex Hd. (Model 6801 ML-134094)	2
31	WS-018-40	Washer (Model 6801 ML-134094)	2
32	00-292284	Screw – Jack (Model 6801 ML-134094)	2
33	WL-006-27	Lockwasher $\frac{3}{8}$ Light (Model 6801 ML-134094)	2
34	NS-018-14	Jam Nut $\frac{3}{8}$ -16 Hex (Model 6801 ML-134094)	2
35	SC-041-31	Cap Screw $\frac{3}{8}$ -16 x $1\frac{1}{4}$ Hex Hd. (Model 6801 ML-134094)	2
36	WL-006-27	Lockwasher $\frac{3}{8}$ Light (Model 6801 ML-134094)	2
37	00-291958-00002	Brace – Carriage Support (Model 6801 ML-134094)	2
38	NS-015-11	Nut $\frac{5}{16}$ -18 Hex	5
39	WL-006-23	Lockwasher $\frac{5}{16}$ Medium (SST)	5
40	WS-017-21	Washer	5
41	00-290790	Tray – Scrap (Model 6801 ML-134094)	1
42	00-875065	Tray – Scrap (Model 6614 ML-134096)	1
43	WS-018-40	Washer	2
44	SC-041-29	Cap Screw $\frac{3}{8}$ -16 x $\frac{7}{8}$ Hex Hd. Wax Coated Threads (Model 6801 ML-134094)	2
45	SC-041-34	Cap Screw $\frac{3}{8}$ -16 x 2 Hex Hd. (Model 6614 ML-134096)	2
46	SC-124-44	Bolt – Sq. Neck $\frac{5}{16}$ -18 x $\frac{3}{4}$ Rd. Hd.	5

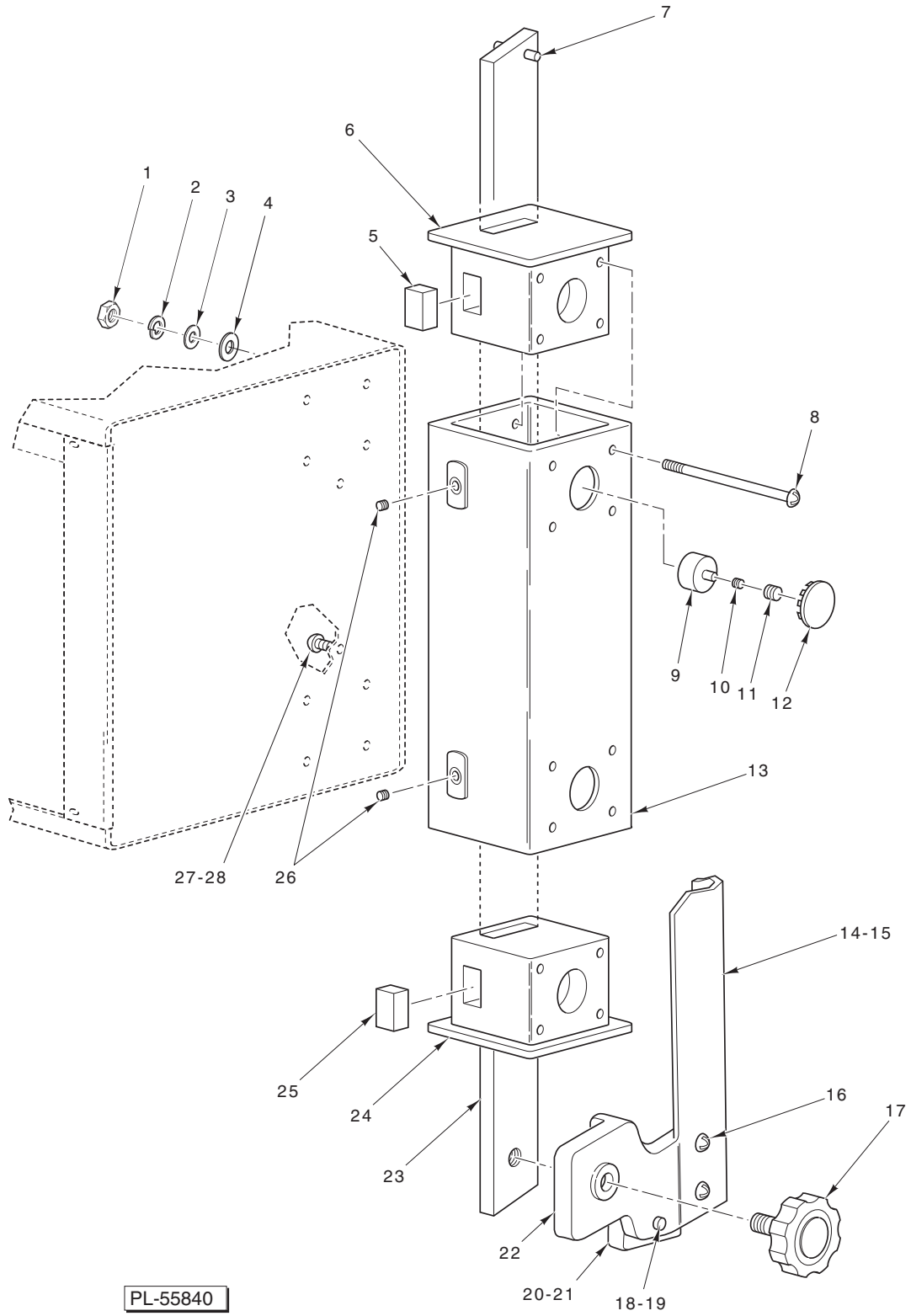

UPPER GUIDE UNIT

UPPER GUIDE UNIT

ILLUS. PL-55840	PART NO.	NAME OF PART	AMT.
1	NS-011-12	Mach. Nut 8-32 Hex	8
2	WL-014-05	Lockwasher #8 External Shakeproof	8
3	WS-023-22	Washer	8
4	WS-031-35	Washer	8
5	00-479766	Slide Lock	1
6	00-478999	Guide Bar Insert	1
7	PG-007-16	Groove Pin $\frac{3}{16}$ Dia. x $\frac{3}{4}$ Lg.	1
8	SC-021-17	Mach. Screw 8-32 x $2\frac{1}{2}$ Rd. Hd.	8
9	00-120141	Shoe – Slide Rod	2
10	00-873782	Spring – Slide Rod	2
11	SC-046-70	Set Screw $\frac{3}{8}$ -16 x $\frac{1}{2}$ Hdls., Cup Pt.	2
12	PB-005-09	Plug Button	2
13	00-478998	Support – Guide Bar	1
14	00-875056	Guard – Front Blade (Model 6614 ML-134096)	1
15	00-291441	Guard – Front Blade (Model 6801 ML-134094)	1
16	SC-053-05	Mach. Screw 10-24 x $\frac{3}{8}$ Truss Hd., Slotted	2
17	00-435958-00002	Knob – Adjusting	1
18	SC-041-02	Cap Screw $\frac{1}{4}$ -20 x 1 Hex Hd. (Lower Guide)	1
19	00-291579	Washer – Guide	1
20	00-290844-00001	Guide – Saw Blade (0.022" Blade)	1
21	00-290844-00002	Guide – Saw Blade (0.014" Blade)	1
22	00-290842	Holder – Upper Guide	1
23	00-873204	Upper Guide Support Bar Assy (Incls. Item 7)	1
24	00-478999	Guide Bar Insert	1
25	00-479766	Slide Lock	1
26	SC-055-01	Set Screw 10-24 x $\frac{1}{4}$ Soc. Hdls., Cup Pt. (SST)	2
27	SC-025-33	Mach. Screw 8-32 x $\frac{1}{2}$ Bndg. Hd.	2
28	NS-011-12	Mach. Nut 8-32 Hex	2

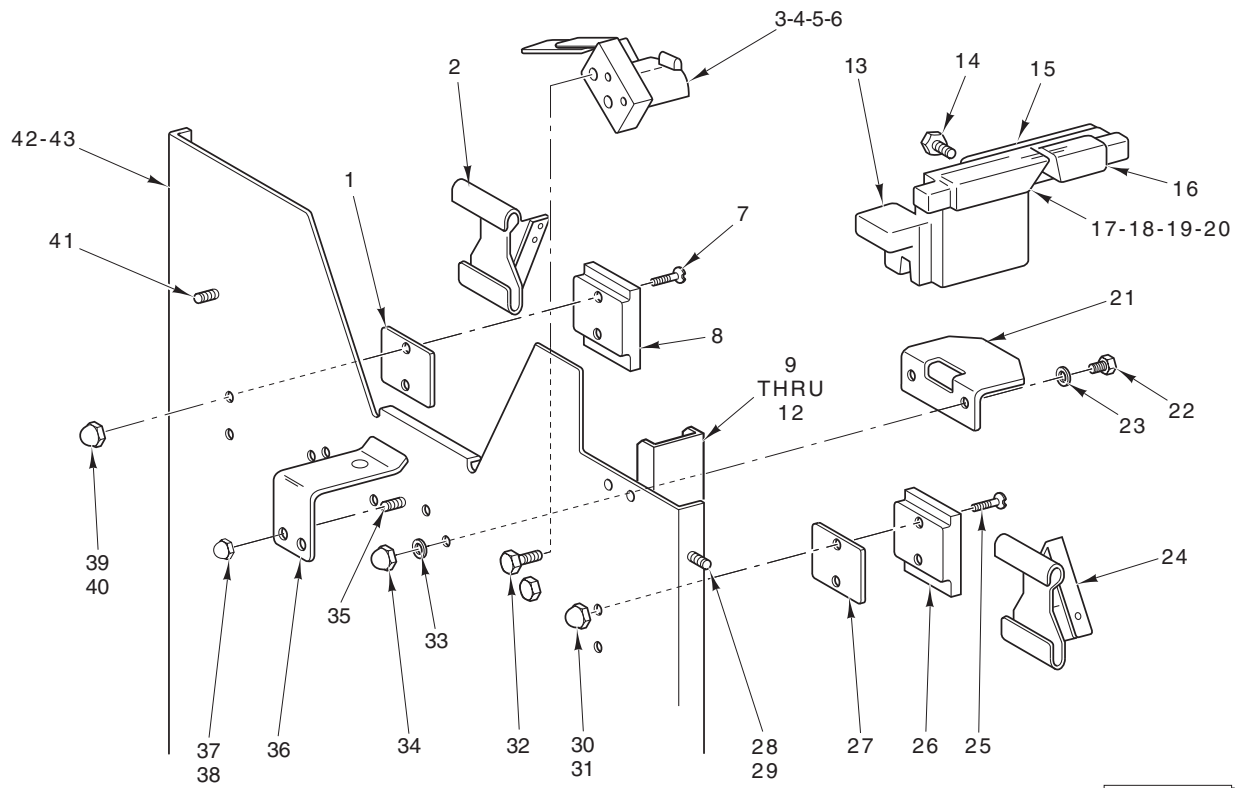

PL-55841

LOWER WIPER UNIT

LOWER WIPER UNIT

ILLUS.	PART NO.	NAME OF PART	AMT.
PL-55841			
1	00-290855	Shim – Wiper Support	AR
2	00-290798	Blade Wiper Assy.	1
3	00-291831	Block – Pulley Wiper	1
4	00-102399	Pulley Wiper Assy. (Incls. Items 5 & 6)	1
5	00-123886	Wiper – Pulley	1
6	SC-053-01	Mach. Screw 10-24 x 1/4 Truss Hd.	2
7	SC-022-35	Mach. Screw 1/4-20 x 3/4 Flat Hd.	2
8	00-290822	Support – Wiper	1
9	00-291809	Shield – Blade Guide	1
10	SC-041-86	Cap Screw 1/4-20 x 3/8 Hex Hd.	2
11	WS-003-49	Washer	2
12	NS-025-04	Acorn Nut 1/4-20	2
13	00-875234-00002	Holder – Lower Guide	1
14	SC-116-26	Cap Screw 1/4-28 x 7/8 Hex Hd.	2
15	00-875235	Cover – Guide	1
16	00-291658	Guide – Plastic	1
17	00-291670-00001	Guide – Saw Blade (0.022" Blade)	1
18	00-291670-00002	Guide – Saw Blade (0.014" Blade)	1
19	00-291670-00003	Guide – Saw Blade (0.038" Blade)	1
20	00-291670-00004	Guide – Saw Blade (0.020" Blade)	1
21	00-875246	Support	1
22	SC-041-50	Cap Screw 1/4-20 x 1/2 Hex Hd.	2
23	WS-003-49	Washer	AR
24	00-290798	Blade Wiper Assy.	1
25	SC-022-35	Mach. Screw 1/4-20 x 3/4 Flat Hd.	2
26	00-290822	Support – Wiper	1
27	00-290855	Shim – Wiper Support	AR
28	SC-041-50	Cap Screw 1/4-20 x 1/2 Hex Hd.	2
29	WS-003-49	Washer	2
30	NS-025-04	Acorn Nut 1/4-20	2
31	WS-003-49	Washer	2
32	SC-041-86	Cap Screw 1/4-20 x 3/8 Hex Hd.	2
33	WL-006-17	Lockwasher 1/4 Medium (Model 6614 ML-134096)	2
34	NS-025-04	Acorn Nut 1/4-20	2
35	SC-025-07	Mach. Screw 10-24 x 5/16 Bndg. Hd.	2
36	00-290788	Clip – Cover	1
37	NS-025-01	Nut – Crown 10-24	2
38	WL-006-06	Lockwasher #10 Light	2
39	NS-025-04	Acorn Nut 1/4-20	2
40	WS-003-49	Washer	2
41	SC-041-50	Cap Screw 1/4-20 x 1/2 Hex Hd.	2
42	00-875082	Baffle – Lower Pulley (Model 6614 ML-134096)	2
43	00-290851-00002	Baffle – Lower Pulley (Model 6801 ML-134094)	1
	00-291672-00001	Holder & Guide Assy. (Incls. Items 13 thru 17)	1
	00-291672-00002	Holder & Guide Assy. (Incls. Items 13 thru 16 & 18)	1
	00-291672-00003	Holder & Guide Assy. (Incls. Items 13 thru 16 & 19)	1
	00-291672-00004	Holder & Guide Assy. (Incls. Items 13 thru 16 & 20)	1

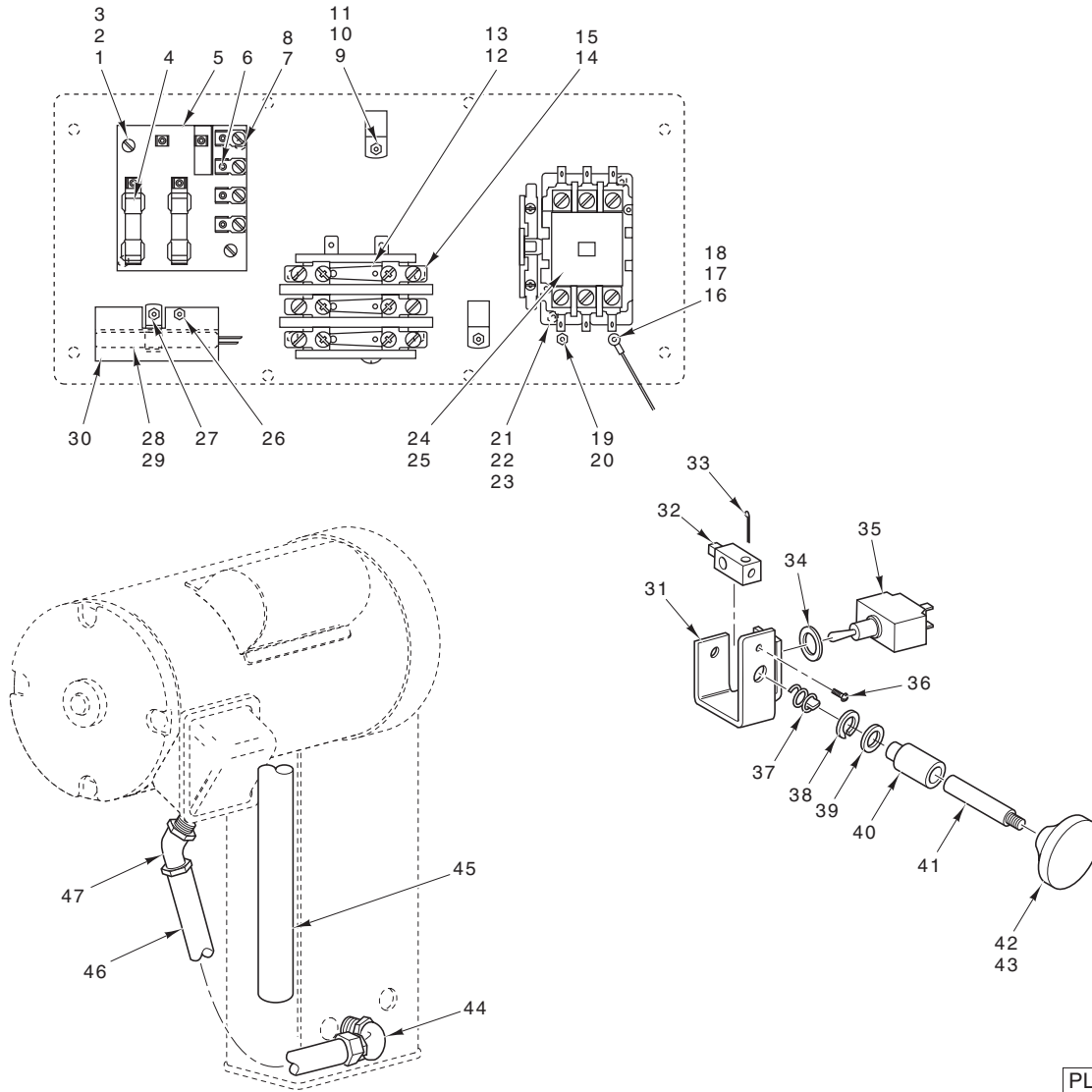

PL-55843

ELECTRICAL UNIT

ELECTRICAL UNIT

ILLUS.	PART NO.	NAME OF PART	AMT.
	PL-55843		
1	SC-025-33	Mach. Screw 8-32 x 1/2 Bndg. Hd.	2
2	WL-014-05	Lockwasher #8 External Shakeproof	2
3	NS-011-12	Mach. Nut 8-32 Hex	2
4	FE-019-48	Fuse (0.8 Amp.) (600 V.)	2
5	00-120907-00001	Transformer (50 VA.)	1
6	00-114707	Fuse Board	1
7	NS-011-12	Mach. Nut 8-32 Hex	2
8	WL-014-05	Lockwasher #8 External Shakeproof	2
9	NS-011-12	Mach. Nut 8-32 Hex	3
10	WS-023-22	Washer	3
11	00-078752-00009	Clamp – Cable	3
*12	-	Heater – Element (Overload Relay)	AR
13	00-088196-009-1	Relay – Thermal Overload (3 Ph.) (W/Overload Protection)	1
14	NS-011-12	Mach. Nut 8-32 Hex (Model 6801 ML-134094)	2
15	WL-014-05	Lockwasher #8 External Shakeproof	2
16	00-290889	Cable & Eyelet Assy. (Panel to Column)	1
17	NS-011-12	Mach. Nut 8-32 Hex	2
18	WL-014-05	Lockwasher #8 External Shakeproof	2
19	NS-011-12	Mach. Nut 8-32 Hex	1
20	WL-014-05	Lockwasher #8 External Shakeproof	1
21	NS-011-12	Mach. Nut 8-32 Hex	2
22	WS-023-22	Washer	1
23	WL-014-05	Lockwasher #8 External Shakeproof	2
24	00-087713-101-1	Contactory Assy. (3 Pole) (200-230 V.)	1
25	00-087713-101-2	Contactory Assy. (3 Pole) (460 V.)	1
26	NS-011-12	Mach. Nut 8-32 Hex	2
27	00-108199-00001	Clamp – Air Heater	1
28	00-122345-00001	Heater Assy. (460 V.)	1
29	00-122345-00002	Heater Assy. (200-230 V.)	1
30	00-121543	Shield – Heater	1
31	00-123241-00001	Bracket – Switch	1
32	00-873781	Actuator Switch	1
33	PC-005-08	Cotter Pin 3/32 x 5/8 Lg.	1
34	00-121827	Ring – Locking	1
35	00-120388	Switch & Label Assy.	1
36	SC-053-05	Mach. Screw 10-24 x 5/8 Truss Hd.	2
37	00-121547	Spring – Compression	1
38	00-875049	Retaining Ring	1
39	WS-018-30	Washer	1
40	00-290883	Bushing – Switch Shaft	1
41	00-290882	Shaft – Switch	1
42	00-291475	Label – Start/Stop	1
43	00-290885	Knob – Switch	1
44	FE-024-61	Connector 1/2 x 45 Deg. (Non-Metallic) Sealrite	1
45	00-291600	Tube – Insulator	1
46	00-436913-00012	Conduit – 1/2 Liquidite	1
47	FE-024-61	Connector 1/2 x 45 Deg. (Non-Metallic) Sealrite	1

*Give Elec. Spec., Mach. Model, & Motor Type.

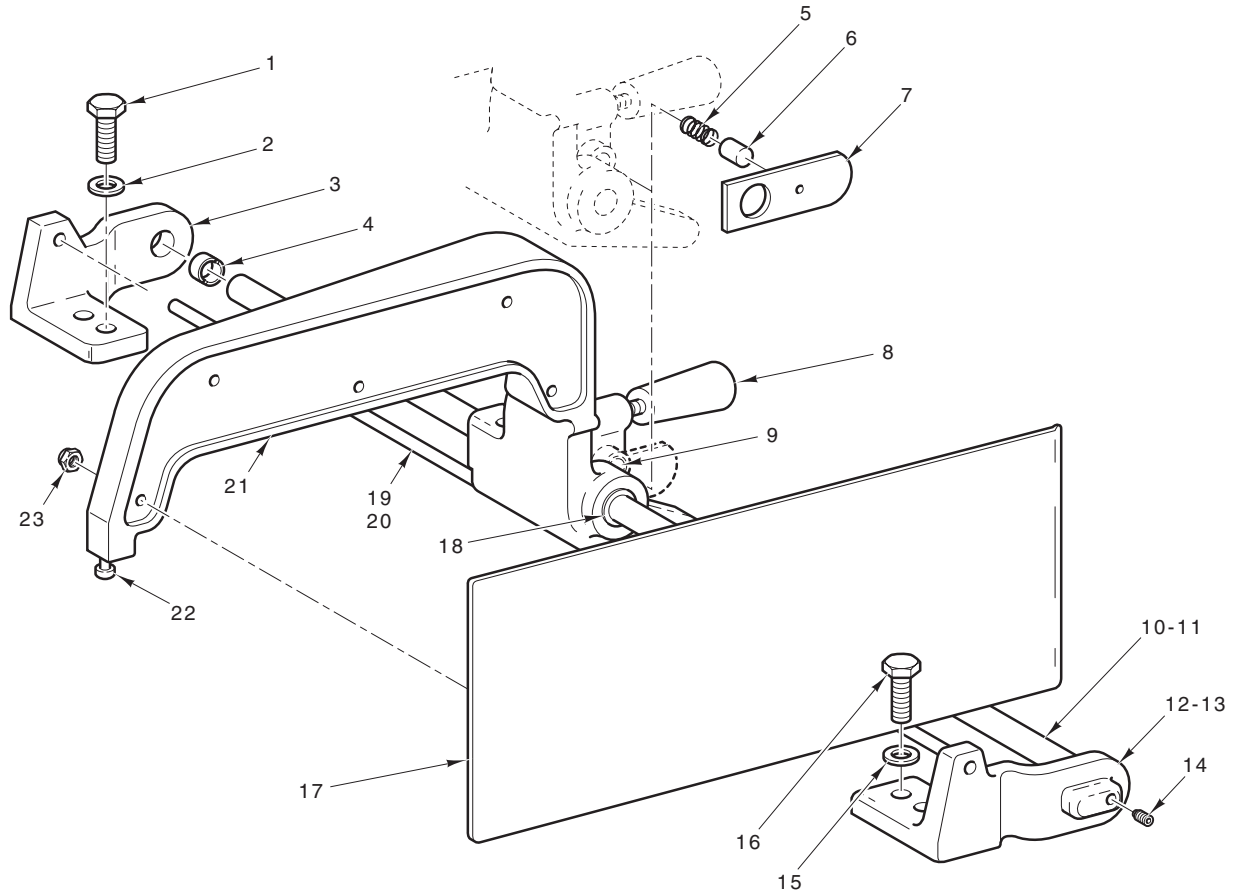

PL-55844

GAUGE PLATE UNIT

ILLUS.	PART NO.	NAME OF PART	AMT.
	PL-55844		
1	SC-041-31	Cap Screw 3/8-16 x 1 1/4 Hex Hd.	2
2	WS-018-40	Washer	2
3	00-873712-00002	Support – Shaft & Rod (Rear)	1
4	00-479644	Bearing – Sleeve	2
5	00-291933	Spring – Gauge Plate Lock	1
6	00-291932	Pin – Locking Lever	1
7	00-290769	Lever – Locking	1
8	00-070194	Handle – Gauge Plate	1
9	00-110544-00010	Bushing – Gauge Plate Frame	1
10	00-290770-00003	Shaft – Gauge Plate (Model 6614 ML-134096)	1
11	00-290770	Shaft – Gauge Plate (Model 6801 ML-134094)	1
12	00-873712-00002	Front Shaft & Rod Support Assy. (Incls. Items 13 & 14)	1
13	PG-006-11	Pin – Groove 1/4 x 5/8 Type D	1
14	SC-064-27	Set Screw 5/16-18 x 1/2 Soc. Hlds., Cup Pt. Nylok	1
15	WS-018-40	Washer	2
16	SC-041-31	Cap Screw 3/8-16 x 1 1/4 Hex Hd.	2
17	00-291431	Plate and Stud Assy.	1
18	00-110544-00009	Bushing – Gauge Plate Frame	2
19	00-290758-00004	Rod – Table Anchor (Right Table) (Model 6614 ML-134096)	1
20	00-290758-00002	Rod – Table Anchor (Right Table) (Model 6801 ML-134094)	1
21	00-291944	Gauge Plate Assy. (Incls. Items 9, 17, 18, 22, & 23)	1
22	00-290764	Button – Glide	1
23	NS-025-04	Acorn Nut 1/4-20	5
	00-292347	Gauge Plate Assy. (Incls. Items 5, 6, 7, 17, 21, & 22) (Pkgd.)	1