

view "Z1"

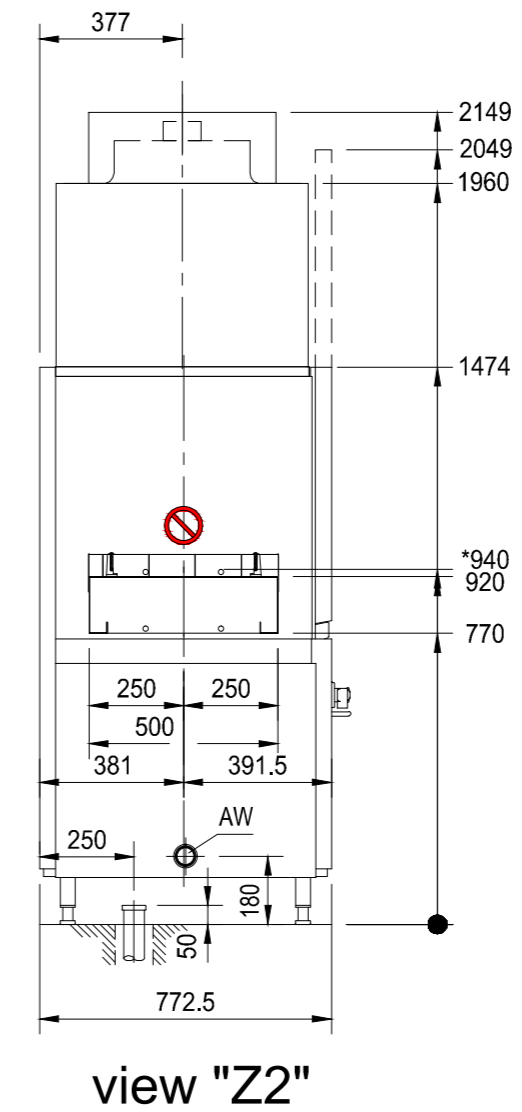

view "Z2"

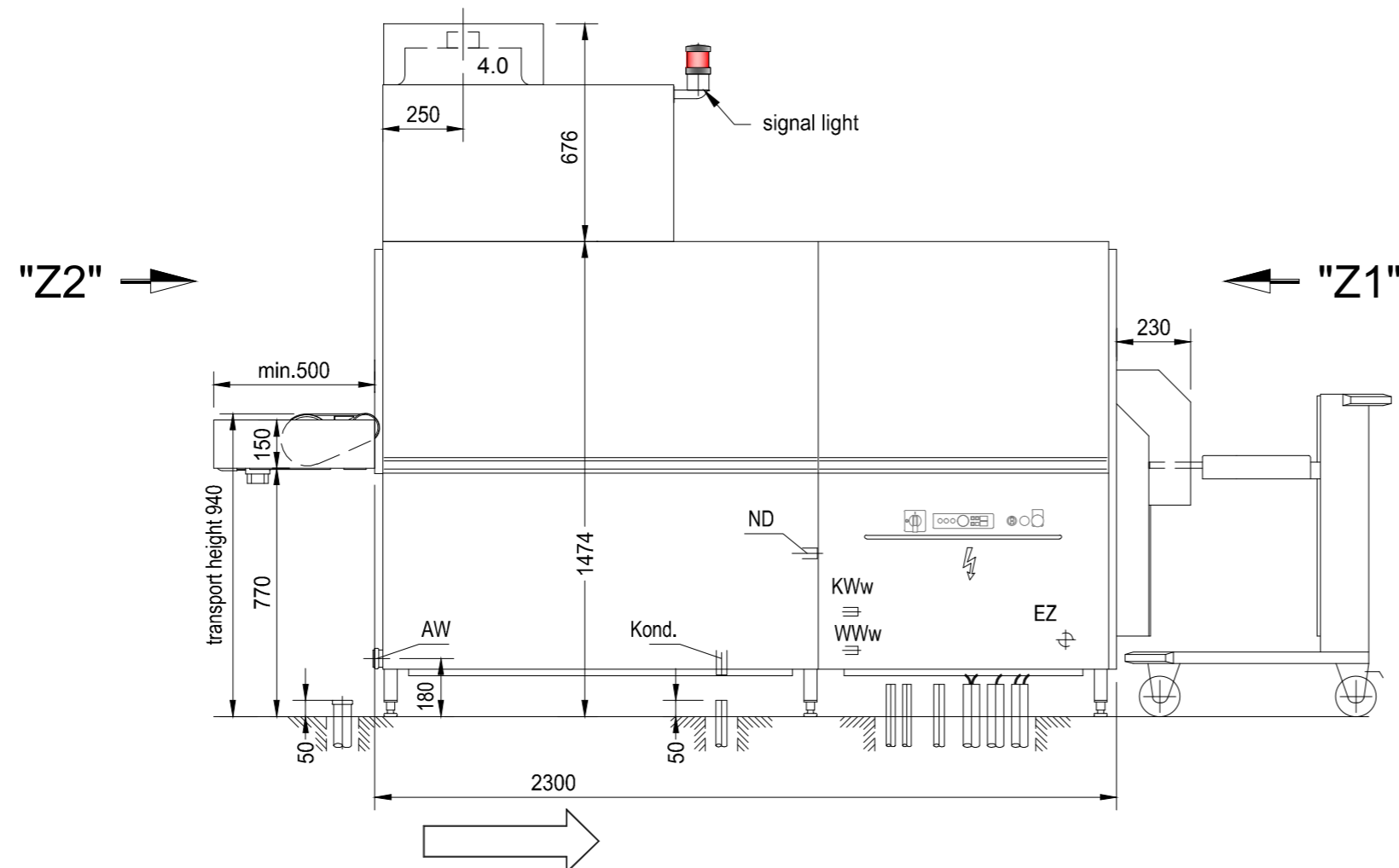
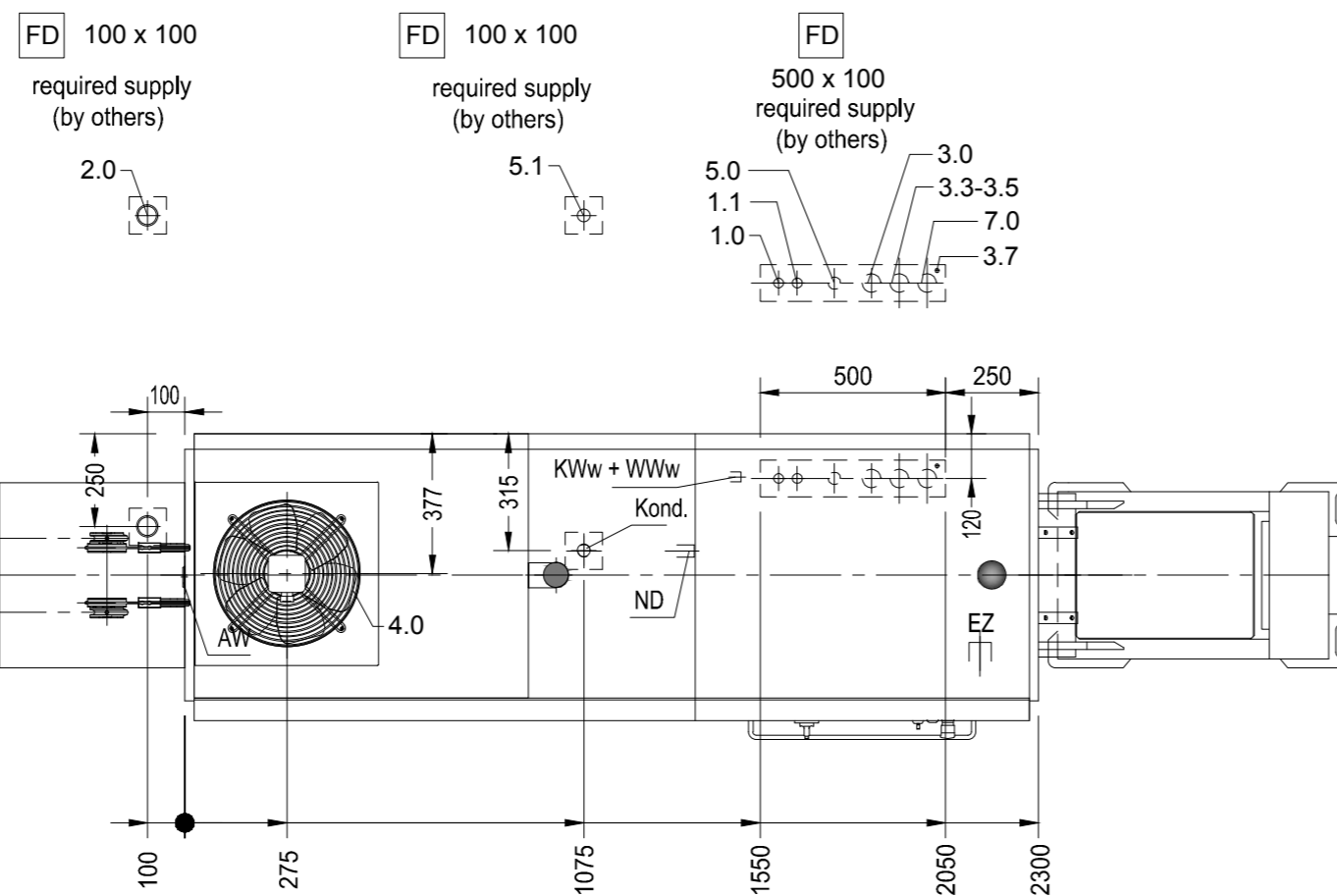

FTT; THP L/R - steam

Machine-Type:	Tray Washer		Heating:	Steam
Model:	FTT	FTT; THP	Operation:	Left / Right
Usable-Width:	500	Usable-Height:	40	Main-Switch: Built in Machine
Chemical	conduit for chemical supply			Dimension: DN50, Position in mm: 100mm AFFL
Heating	Consumption		Dimension: DN25	Connection: G1" male, Position in mm: 50mm AFFL
5.1	Condensate	23,5 kg/h	49037 kJ/h	
5.0	Steam			DN25, G1 (welding fitting), 100mm AFFL
Steam-Flow-Pressure provided by customer: 0,5-1,0 bar				
Exhaust	Volume	Temp.	Rel. Humidity	Pressure
4.0	350 m³/h	18-22°C	90-98%	ca. 0 Pa
Exhaust	Control and Data-Line			Extended-Length
3.7	Equipotential	min. 1x6mm² provided by customer		3m reserve
3.5	Malfunction-Sensor		5x1,5 mm²	STL, 3m reserve
3.4	Exhaust		3x1,5 mm²	STL, 3m reserve
3.3	Dosage-System		7x1,5 mm²	STL, 3m reserve
Exhaust	Voltage	Frequency	Supply	Fuse
3.0	400 V	50 HZ	3-N-PE	3x35 A
				Cross-Section: 5x6 mm², Power: 13,5 kW, Extended-Length: 3m reserve
Water	Consumption	Temp.	Hardness	Conductance
2.0	105 l (Filling)	50-60 °C	max. 7°d (1,2mmol/l)	150-400µS/cm
1.1	200 l/h	12 °C	0-3°d (0,5mmol/l)	80-120µS/cm
1.0				Dimension: DN20, Connection: G3/4" male, Position in mm: 100mm AFFL
Water-Flow-Pressure provided by customer: min. 1,5 bar / 22 psi				
Heat-Radiation (thermal output to the room)				
	washware	5,8 kW	latent	1,3 kW
			sensibel	4,6 kW

HOBART GENERAL INFORMATION

Installation: All installations should always comply with all national and local codes of practice.

Exhaust: A frost-protection flap is recommended if the exhaust air from the machine is exterior ducted.

Transport: Minimum measurements of entry doors for machine assembly = outer measurements of largest machine + 300mm in height, + 400mm in width!

Aeration: The ventilation and exhaust for the room must be interpreted according to local by-laws

Heat pump: Proper working order can only be ensured by room temperature above 18°C.

Shut-off valves: The shut-off valves for rinse water, tank filling or demi-rinse are supplied by others.

Control- and data lines: We recommend a conduit for control-lines in the area of the electrical connection.

Washing result: A spotless cleaning results can be achieved only with low mineral content of the rinse water. We recommend a conductance of about 80µS/cm.

Floor drain: Splash floor drains should be installed for general cleaning purpose.

Steam-connections: The in-house steam-flow piping must be equipped with condensate drainage prior to the HOBART steam-connection. The in-house condensate piping must be pressure less and able to absorb all HOBART condensate.

HOBART GENERAL LEGEND

AW = drain water (CNS)	KW = cold water	üOKFF = above finished floor
Dat = dataline	KWw = cold water soft	UK = lower edge
EZ = power line 230V / 400V	LR = conduit Ø	VEW = demineralized water
FD = floor opening	CNS = stainless steel (inox)	WD = wall opening
HW-VL = hot water flow	MK = supply channell	WS = wall slot
HW-RL = hot water return	PE = equipotential conductor	WW = warm water
ND = low pressure steam	STL = control line	WWw = warm water soft
Kond. = condensate	KB = cored hole Ø	

Das Urheberrecht an dieser Zeichnung verbleibt bei der HOBART GmbH.
 Jede nicht von uns schriftlich genehmigte Benutzung, Verfielfältigung, Überlassung an Dritte ist strafbar und macht schadensersatzpflichtig.
 This document contains proprietary and confidential data of HOBART GmbH. No disclosure, reproduction or use of any part thereof may be made without written permission of HOBART GmbH.

HOBART HOBART GmbH - Robert-Bosch-Straße17 - 77656 Offenburg, Germany
 Tel.: +49(0)781.600-0 - Fax.: +49(0)781.600-2319 - www.hobart.de

Index Änderungen / Changes Datum / Date Name

Datum / Date: 2012 / AUGUST
 Gezeichnet / Drawn by: WH
 Geprüft / Checked by: W: Neumaier
 Projectmanager:

Project: TRAY WASHER FTT
 HEATPUMP THP
 STEAM HEATED

Maßstab / Scale: 1:20
 Order-No.:
 Zeichnungsnummer / Drawing-No.: 31 FTT THP - steam LR

release 2012.08 DIN A2 Sheet 1/1